

# MC-25

Delay-on-make / Delay-on-break  
time relay

## DESCRIPTION



## TECHNICAL SPECIFICATIONS

Power supply:	15 – 24 VAC/VDC -5 – 10%
Operating frequency:	4 MHz (microprocessor)
Power consumption:	10 mA at rest; 50 mA max.
Output:	2 SPST relays
Max. voltage (relay contact):	30 VDC / 120 VAC
Max. current (relay contacts):	1.0A DC / 0.5A AC

*Specifications are subject to change without prior notice.*

*All values measured in specific conditions.*

## PRECAUTIONS



**CAUTION**

- Shut off all power going to header before attempting any wiring procedures.
- Maintain a clean and safe environment when working in public areas.
- Constantly be aware of pedestrian traffic around the door area.
- Always stop pedestrian traffic through the doorway when performing tests that may result in unexpected reactions by the door.
- ESD (electrostatic discharge):* Circuit boards are vulnerable to damage by electrostatic discharge. Before handling any board, ensure you dissipate your body's ESD charge.
- Always check placement of all wiring before powering up to ensure that moving door parts will not catch any wires and cause damage to equipment.
- Ensure compliance with all applicable safety standards (i.e. ANSI A156.10) upon completion of installation.
- DO NOT attempt any internal repair of the components. All repairs and/or component replacements must be performed by BEA, Inc. Unauthorized disassembly or repair:
  1. May jeopardize personal safety and may expose one to the risk of electrical shock.
  2. May adversely affect the safe and reliable performance of the product resulting in a voided warranty.

# WIRING

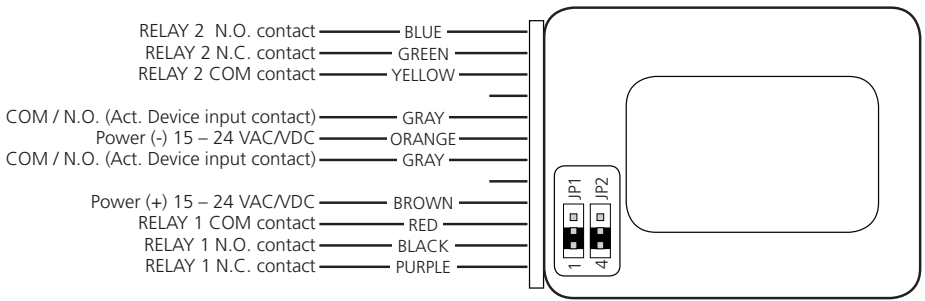

# ELECTRICAL INSTALLATION

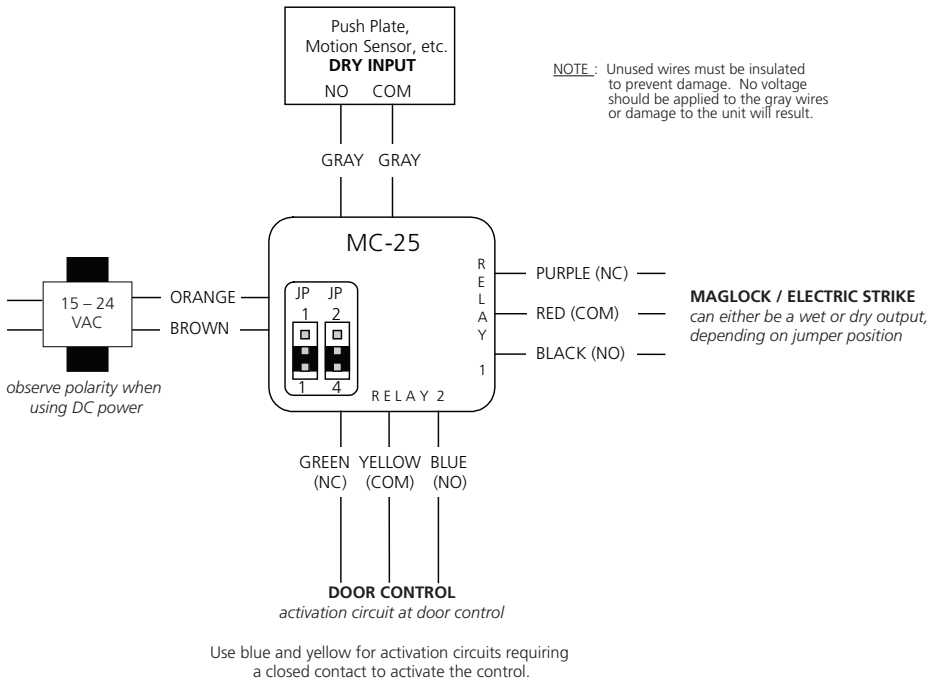

# MODULE SETTINGS

JUMPER SETTINGS: choice of wet or dry output for RELAY 1

DRY (no voltage/current supplied by time delay) = both jumpers on left and middle pins

WET (voltage/current supplied by time delay) = both jumpers on right and middle pins

*supplied voltage = input voltage*

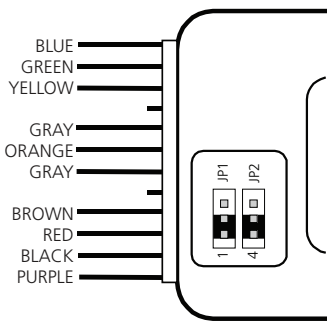

DRY OUTPUT ON RELAY 1

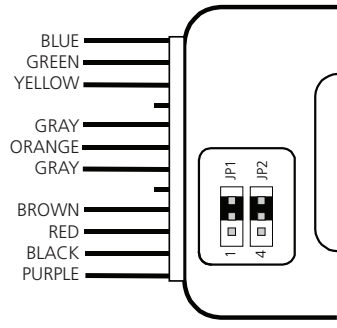

WET OUTPUT ON RELAY 1

DIP SWITCH SETTINGS: hold-open time delay

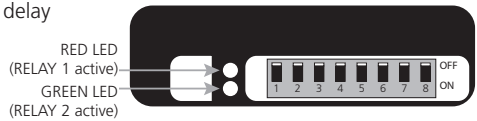

## RELAY 1:

Adjustable from 0 to 7 seconds; red LED on for duration of time delay set on RELAY 1; independent of time delay set on RELAY 1, RELAY 2 activates 0.5 or 1.5 seconds after RELAY 1 begins.

TIME DELAY (sec)	DIP 1 (1 sec)	DIP 2 (2 sec)	DIP 3 (4 sec)
1	ON	OFF	OFF
2	OFF	ON	OFF
3	ON	ON	OFF
4	OFF	OFF	ON
5	ON	OFF	ON
6	OFF	ON	ON
7	ON	ON	ON

## RELAY 2:

Time delay set to RELAY 2 is the hold open time delay for the door; adjustable from 0 to 15 seconds; green LED indicates RELAY 2 is active and sending signal to door control to hold door open.

TIME DELAY (sec)	DIP 4 (1 sec)	DIP 5 (2 sec)	DIP 6 (4 sec)	DIP 7 (8 sec)
1	ON	OFF	OFF	OFF
2	OFF	ON	OFF	OFF
3	ON	ON	OFF	OFF
4	OFF	OFF	ON	OFF
5	ON	OFF	ON	OFF
6	OFF	ON	ON	OFF
7	ON	ON	ON	OFF
8	OFF	OFF	OFF	ON
9	ON	OFF	OFF	ON
10	OFF	ON	OFF	ON
11	ON	ON	OFF	ON
12	OFF	OFF	ON	ON
13	ON	OFF	ON	ON
14	OFF	ON	ON	ON
15	ON	ON	ON	ON

## DELAY OPTION:

Time delay between Relay 1 being activated and Relay 2 being activated.

TIME DELAY (sec)	DIP 8
0.5	OFF
1.5	ON

## TROUBLESHOOTING

PLEASE KEEP FOR FURTHER USE – DESIGNED FOR COLOR PRINTING

Door sequencer will not activate	Faulty power supply or activation input	Ensure correct power supply of 15 – 24 VAC / VDC. Power should come from an isolated transformer – not from the door control.
Door stays open too long	Total time delay between the door sequencer and the door control is too long	Check for proper power at the orange and brown wires of the Door Sequencer. If power source is good, but not present at the connector, check the orange and brown wires for continuity with an ohm meter. Replace as necessary.
Door unlocks but will not open	Lock device is drawing too much from the power supply	When powering with DC power, observe polarity. Orange must be (-) and brown must be (+). Using a multi-meter, check both gray wires for continuity.
		For hold-open time, use the Time Delay Module timer if the door control does not have a time-delay adjustment. If it does, set the Time Delay Module to the minimum setting, and use the door control's hold time exclusively.
		Install separate power supply for lock device.

@BEA | Original Instructions | 75.0066.07 MC-25 20180913

A HALMA COMPANY

### BEA INSTALLATION/SERVICE COMPLIANCE EXPECTATIONS

BEA, the sensor manufacturer, cannot be held responsible for incorrect installations or inappropriate adjustments of the sensor/device; therefore, BEA does not guarantee any use of the sensor outside of its intended purpose.

BEA strongly recommends that installation and service technicians be AAADM-certified for pedestrian doors, IDA-certified for doors/gates, and factory-trained for the type of door/gate system.

Installers and service personnel are responsible for executing a risk assessment following each installation/service performed, ensuring that the sensor system installation is compliant with local, national, and international regulations, codes, and standards.

Once installation or service work is complete, a safety inspection of the door/gate shall be performed per the door/gate manufacturer recommendations and/or per AAADM/ANSI/DASMA guidelines (where applicable) for best industry practices. Safety inspections must be performed during each service call – examples of these safety inspections can be found on an AAADM safety information label (e.g. ANSI/DASMA 102, ANSI/DASMA 107).

Verify that all appropriate industry signage and warning labels are in place.



Tech Support: 1-800-407-4545 | Customer Service: 1-800-523-2462  
General Tech Questions: [Tech\\_Services@beainc.com](mailto:Tech_Services@beainc.com) | Tech Docs: [www.BEAinc.com](http://www.BEAinc.com)

