

# LZR<sup>®</sup>-FLATSCAN U950 LZR<sup>®</sup>-FLATSCAN U952

LASER MEASUREMENT DEVICE  
WITH BIDIRECTIONAL BUS COMMUNICATION



*Visit website for  
available languages  
of this document.*

## INSTALLATION SAFETY TIPS

- The door control unit and the header cover profile must be correctly grounded.
- Only trained and qualified personnel are recommended to install and set up the sensor.
- Always test for proper operation before leaving the premises.
- Do not remove the laser window protection if building works are still in progress on site.



The device emits invisible (IR) laser radiation.

IR laser: wavelength 905nm; output power 0.10mW  
(Class 1 according to IEC 60825-1)

**Do not stare into laser emitter.**

## INSTALLATION TIPS

- Remove the laser window protection before teach-in and commissioning.
- Avoid vibrations.
- Do not cover the laser window.
- Avoid moving objects and light sources in the detection field.
- Avoid the presence of smoke and fog in the detection field.
- Avoid condensation.
- Avoid exposure to sudden and extreme temperature changes.
- Ensure power to the sensor in areas where the temperature can reach below 14 °F.

## MAINTENANCE TIPS

- When needed, wipe the laser window only with a soft, clean and damp microfiber cloth.
- Do not use dry or dirty towels or aggressive products to clean the laser window.
- Avoid direct exposure to high-pressure cleaning.
- The warranty is invalid if unauthorized repairs are made or attempted by unauthorized personnel.
- To open an already mounted sensor, position a screwdriver in the notch and pull upwards until the cover comes loose. See *image*.

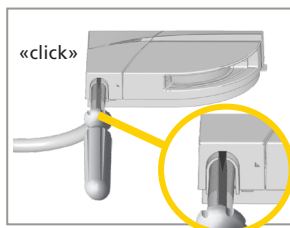

## BEA, INC. INSTALLATION/SERVICE COMPLIANCE EXPECTATIONS

The installation is provided by CUSTOMER or its affiliates. BEA is not affiliated with CUSTOMER or any of its affiliates. BEA has no liability to CUSTOMER or the end user for any and all liability, claims, demands, obligations, actions, losses, costs, damages, fees or expenses (including attorneys' fees and legal costs) arising out of or in connection with product installation, or the end user's use of or inability to use the product, the installation services, product defects or malfunctions, including, but not limited to, any actual or alleged injury, damage, death or other consequence occurring to any person or property as a result, directly or indirectly, of installation, possession, or use of any product or services provided by CUSTOMER or any individual or entity acting for or on behalf of CUSTOMER, whether claimed by reason of breach of warranty, negligence, product defect or otherwise, and regardless of the form in which any such claim is made (collectively, the "Released Matters"). You, on behalf of yourself and each of the Releasor Parties, hereby releases and absolutely and irrevocably discharges each Hippo Party and their respective officers, directors, employees, representatives and agents from and against any Released Matters. You acknowledge and agree that the foregoing is a full and final release of all Released Matters, including those that are unknown, unanticipated or unsuspected or that may hereafter arise as a result of the discovery of new and/or additional facts, and you expressly waive all rights under Section 1542 of the Civil Code of California as well as any similar statutes of any other jurisdictions, which you acknowledge you have read and understood and which provides as follows: A GENERAL RELEASE DOES NOT EXTEND TO CLAIMS WHICH THE CREDITOR DOES NOT KNOW OR SUSPECT TO EXIST IN HIS FAVOR AT THE TIME OF EXECUTING THE RELEASE, WHICH IF KNOWN BY HIM MUST HAVE MATERIALLY AFFECTED HIS SETTLEMENT WITH THE DEBTOR.

## APPLICATIONS

The LZR-FLATSCAN U is a LASER-based device measuring distances with 1 curtain.

It can be installed to scan in any direction and is designed to provide the highest degree of flexibility.

- Profile analysis
- Traffic control
- Navigation of Automated Guided Vehicles
- Navigation monitoring
- Object measurement / detection
- Position measurement
- Counting

## DESCRIPTION

There are 2 types of LZR-FLATSCAN U – 950 (with housing) and 952 (without housing). Follow the labels to the right throughout this User's Guide to appropriately install your version.

U950

with housing

U952

without housing

U950

1. cover
2. LED
3. main connector
4. angle adjustment screw
5. lock screw
6. laser head
7. laser window
8. laser window protector
9. positioning tabs
10. mounting base
11. power/communication cable (20.5416)

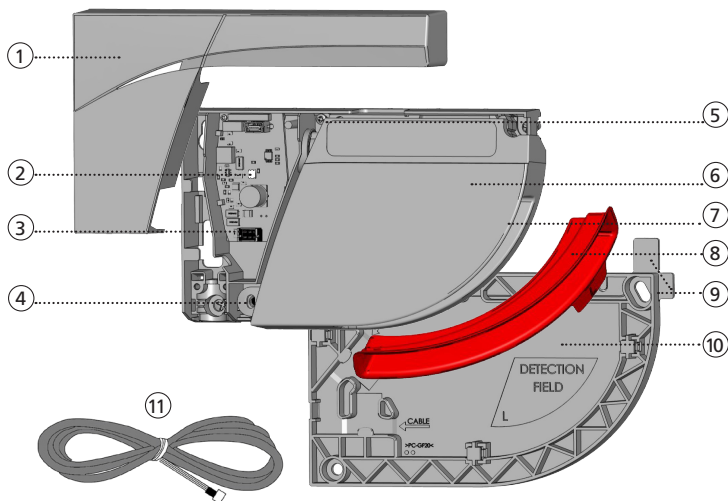

U952

1. LED
2. main connector
3. laser head
4. laser window
5. power/communication cable

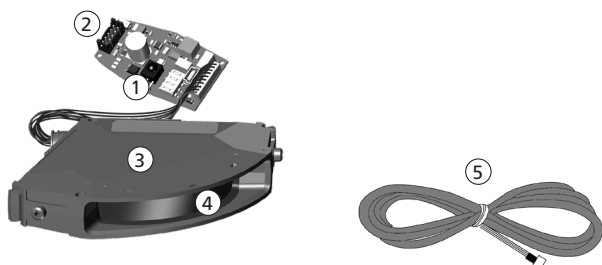

## LED SIGNALS

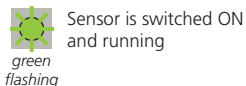
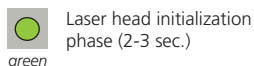

# TECHNICAL SPECIFICATIONS

## TECHNOLOGY / PERFORMANCE

Technology	LASER scanner, time-of-flight measurement
Measurement range	max. 26'3" (8 m) 13' (4m) @ 2% remission factor 26'3" (8m) @ 8% remission factor
Number of planes	1
Number of points/plane*	max. 400 pts
Angular resolution*	min. 0.18°
Angular coverage*	max. 108°
Response time	measurements are refreshed every: 10.75 ms @ angular resolution ≥ 0.74° 43 ms @ angular resolution < 0.74°
Scanning rate	93 scans/sec. @ angular resolution ≥ 0.74° 23.25 scans/sec. @ angular resolution < 0.74°
Emission characteristics	IR LASER: Wavelength 905 nm; max. output pulse power 25 W; Class 1
Measurement error	± 1 <sup>3</sup> / <sub>16</sub> " @ 13' (±30mm @ 4m) ± 2 <sup>3</sup> / <sub>4</sub> " @ 26'3" (±70mm @ 8m)
Repeatability	± <sup>3</sup> / <sub>16</sub> " @ 13' (±5mm @ 4m) ± <sup>25</sup> / <sub>64</sub> " @ 26'3" (±10mm @ 8m)
Serial communication	see LZR®-FLATSCAN U Protocol (available for download on our website)
Type	asynchronous
Interface	RS 485
Communication mode	full-duplex
Transmission speed	max. 921,600 bit/sec (configurable)
Topology	point to point
Symbol coding	1 start bit, 1 stop bit, no parity bit
Type	8 bits
File type	little endian, LSB first
Byte order	1 tri-colored LED: sensor/communication status

## ELECTRICAL

Supply voltage	12 – 24 VDC ±15%
Power consumption	< 2 W
Peak current at power-on	0.8 A (max. 20 ms @ 24 V)

## PHYSICAL

Cable length	8'2-1/2" (2.5m)
Connector	DF11-6DS-2C
Dimensions (U950 only)	5 1/2" (L) × 3 1/8" (H) × 1" (D) [142mm (L) × 85mm (H) × 23mm (D)] mounting bracket + 1/4" (7mm)
Material - Color (U950 only)	PC/ASA - Black
Tilt angles (U950 only)	-2 – 6° (with mounting base) 2 – 10° (without mounting base)
Protection degree (U950 only)	IP54 [IEC 60529]
Temperature range	powered: -22 – 140 °F (-30 – 60 °C) unpowered: 14 – 140 °F (-10 – 60 °C)
Humidity	0 – 95% non-condensing
Vibrations	< 2 G

## COMPLIANCE

Compliance	2014/30/EU; 2011/65/EU; IEC/EN 60825-1 Laser safety; IEC/EN 61000-6-2; IEC/EN 61000-6-3 EMC
------------	---

\* These parameters can be configured via the RS 485 communication interface. For more information on the existing options, see LZR®-FLATSCAN U Protocol.

*Specifications are subject to change without prior notice.  
All values measured in specific conditions.*

# 1 WIRING TO CONTROLLER

U950

U952

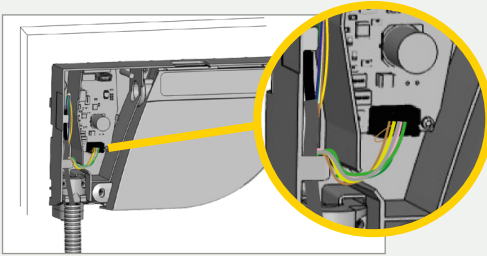

1. Make a loop with the wires of the power cable and pass them through the notch as indicated. Push the excess cable behind the plastic tab as shown.
2. Connect black plug to black connector. *Ensure that the loop does not interfere with the sensor view.*

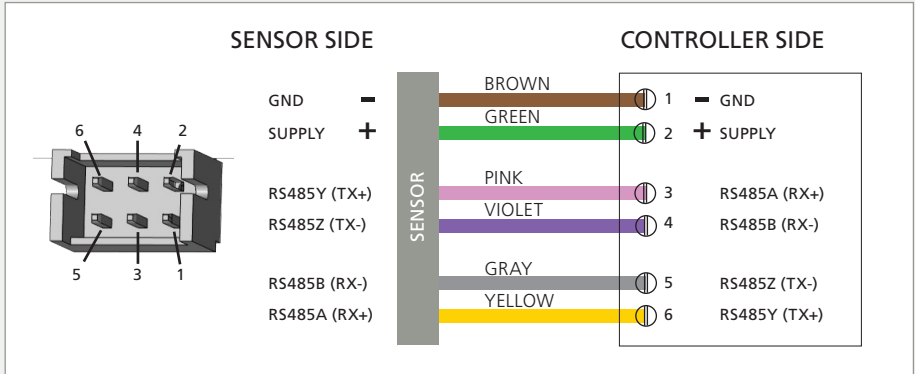

Cut the power cable to the right length, strip the 6 wires and connect all wires as indicated.

 **Observe polarity.**

# 2 MOUNTING

U950

Mounting instructions (next page) apply to both horizontal and vertical mounting orientations.

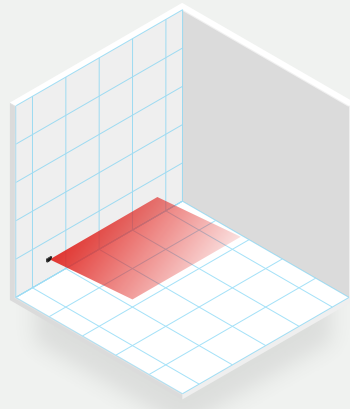
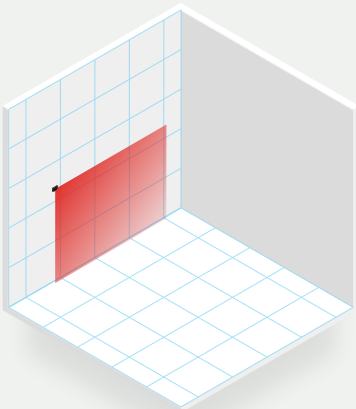

1. Slide the mounting base off of the sensor.

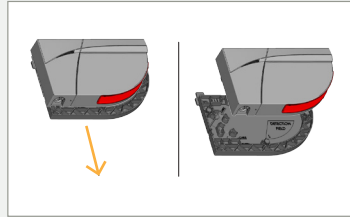

2. Position the mounting base in the desired location. Use the positioning tabs to align the base correctly.
3. Mark and drill the pilot holes ( $\frac{1}{8}$ ").
- Note: You can also use the inner surface of the mounting base to fasten the screws.
4. Using a wire cutter, remove the positioning tabs from the mounting base.
5. Fasten the 3 screws using a screwdriver.

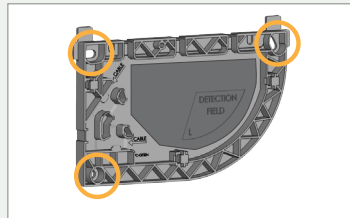

6. Remove the sensor cover by inserting your finger and then pull firmly towards you.

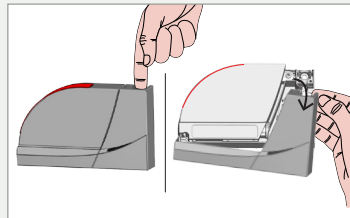

7. Secure the sensor to the mounting base by sliding it downward.

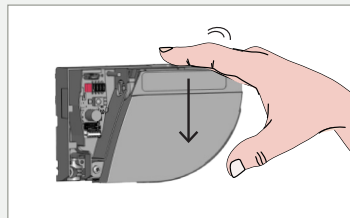

8. Secure the lock screw to avoid vibrations during door movement.

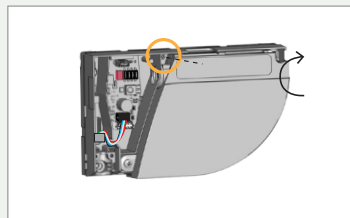

### 3 ADJUSTING THE CURTAIN ANGLE

U950

1. If necessary, adjust the tilt angle of the laser curtain by turning the tilt angle adjustment screw.

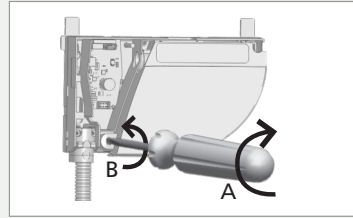
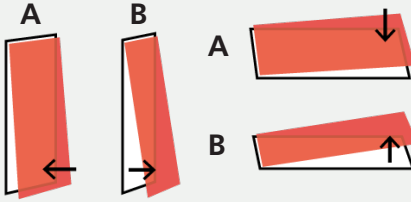

2. Close the cover starting on the narrow side (1). Do not hesitate to push.  
Then press down remaining corners to secure the cover (2).

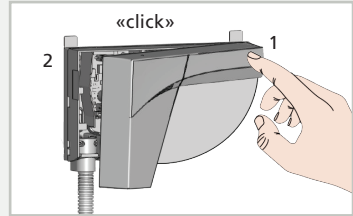

### SPOT SIZE INFORMATION

U950

U952

- a = spot width
- b = spot length
- c = angular resolution

b = 12.5 mrad  
(0.7°)

a = 1.5 mrad (0.09°)

distance	a	b
@ 1 m	1.5 mm	12.5 mm <i>shown</i>
@ 4 m	6 mm	50 mm
@ 8 m	12 mm	100mm

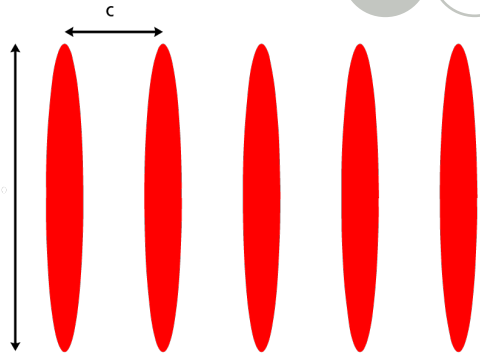



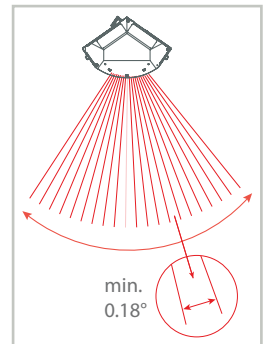

DISTANCE  
BETWEEN  
SPOTS  
("c" above)



To complete sensor setup, visit the BEA Sensors Github page (<https://github.com/BEA-Sensors-Americas>) and access the LZR®-FLATSCAN U Protocol.

## TROUBLESHOOTING

	LED is off	No power	Check the cable and connections.
		Inverted polarity of the power supply	Check the polarity of the power supply.
	ORANGE LED flashes 1x	Internal sensor fault	Cut and restore power supply. If the LED flashes again, replace the sensor.
	ORANGE LED flashes 2x	Power supply is out of limit	Check power supply. If necessary, reduce the cable length or change cable.
	ORANGE LED flashes 3x	Internal communication error	Cut and restore power supply. If the LED flashes again, replace the sensor.



Some errors may not be indicated via the LED.  
In this case, refer to the LZR®-Flatscan U Protocol.

## ADDITIONAL INFORMATION

Additional information about the FLATSCAN U950/952 can be found on the BEA Sensors Github page:  
<https://github.com/BEA-Sensors-Americas>

- FLATSCAN API documentation
- FLATSCAN Visualization software
- protocol documentation