

Input 1 and Input 2 are activation inputs for Door 1 and Door 2 respectively

Inputs 3 and 4 are for the DPSs for Input 1 (Door 1) and Input 2 (Door 2) respectively. Switch is closed when door is closed.

Input 1 and Input 2 are activation inputs for Door 3 and Door 4 respectively

Inputs 3 and 4 are for the DPSs for Input 1 (Door 3) and Input 2 (Door 4) respectively. Switch is closed when door is closed.

Input 1 and Input 2 are activation inputs for Door 5 and Door 6 respectively

Inputs 3 and 4 are for the DPSs for Input 1 (Door 5) and Input 2 (Door 6) respectively. Switch is closed when door is closed.

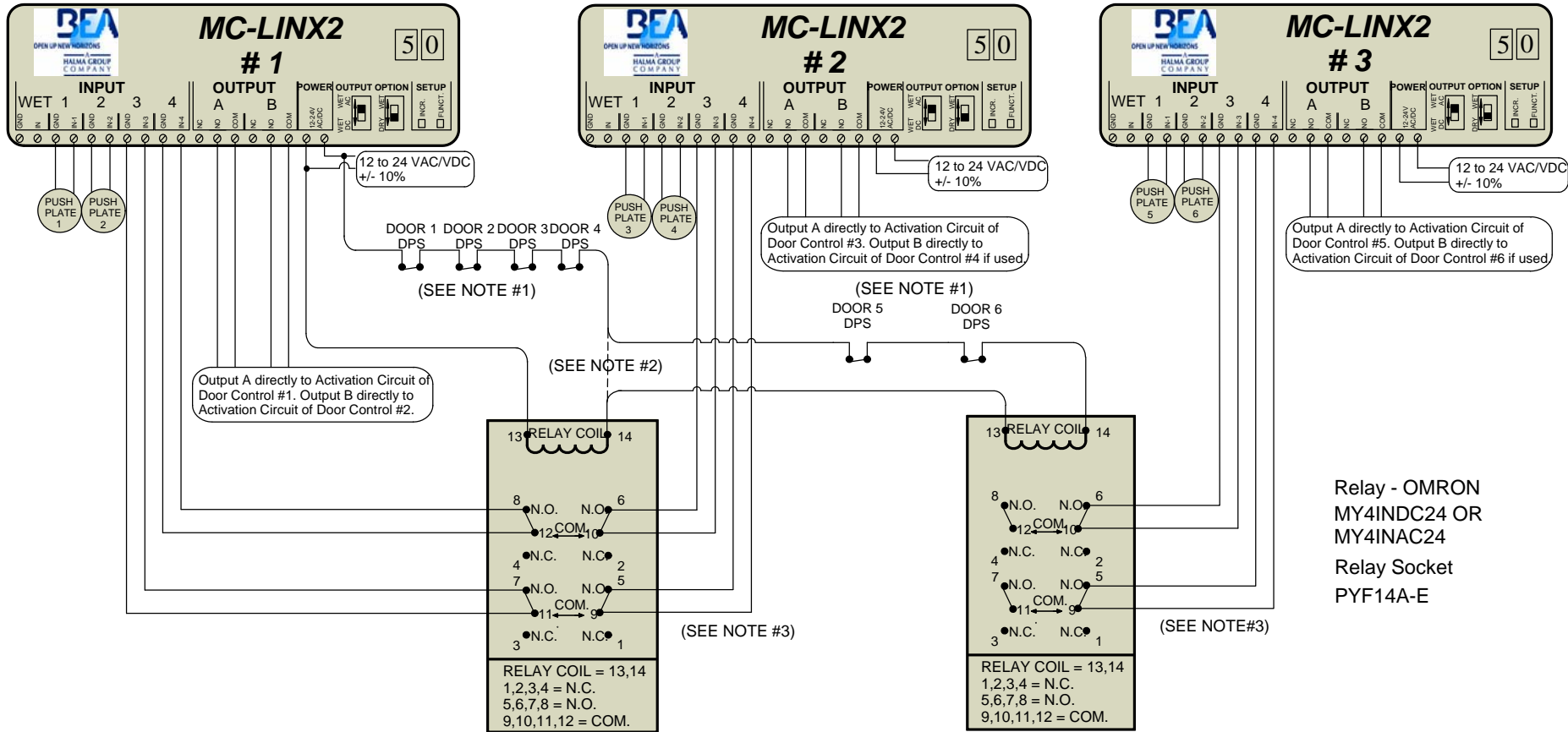

DPS = Door position switch

- NOTES
- 1) DOOR POSITION SWITCHES ARE NORMALLY CLOSED SWITCH IS CLOSED WHEN DOOR IS CLOSED.
 - 2) FOR 3 OR 4 DOOR INTERLOCK ELIMINATE DPS 5, DPS 6, SECOND RELAY AND THIRD MCLINX2.
 - 3) IF IT IS A 3 OR 5 DOOR INTERLOCK INPUT 4 ON EACH MCLINX 2 MUST STILL BE CONNECTED TO THE REPECTIVE RELAY TO WORK PROPERLY.

IF AFTER TROUBLESHOOTING A PROBLEM, A SATISFACTORY SOLUTION CANNOT BE ACHIEVED, PLEASE CALL B.E.A., INC. FOR FURTHER ASSISTANCE DURING EASTERN STANDARD TIME AT 1-800-523-2462 FROM 8AM - 5PM. FOR AFTER-HOURS, CALL EAST COAST: 1-866-836-1863 OR 1-800-407-4545 / MID-WEST: 1-888-308-8843 / WEST COAST: 1-888-419-2564. DO NOT LEAVE ANY PROBLEM UNRESOLVED. IF YOU MUST WAIT FOR THE FOLLOWING WORKDAY TO CALL B.E.A., LEAVE THE DOOR INOPERABLE UNTIL SATISFACTORY REPAIRS CAN BE MADE. NEVER SACRIFICE THE SAFE OPERATION OF THE AUTOMATIC DOOR OR GATE FOR AN INCOMPLETE SOLUTION.WEB: WWW.BEASENSORS.COM

BEA 100 ENTERPRISE DRIVE
 PITTSBURGH, PA 15275
 PHONE: (412) 249-4100
 FAX: (412) 249-4101
 EMAIL: www.beasensors.com

TITLE: MC-LINX2 WITH 3, 4, 5 or 6 DOOR INTERLOCK

SIZE: A	DRAWN BY: WJR	REV BY:	PART NO: 80.0249.03
	SCALE: NONE	DATE: 04 OCT. 2008	SHEET 1 OF 1

