

NOTES: 1) ASTRO-SWING CONTROL BOX MUST BE SET TO CARPET FUNCTION.  
 2) IF BODYGUARD HAS DOM INTERFACE CIRCUIT BOARD, IT MUST BE REMOVED.

IF AFTER TROUBLESHOOTING A PROBLEM, A SATISFACTORY SOLUTION CANNOT BE ACHIEVED, PLEASE CALL B.E.A., INC. FOR FURTHER ASSISTANCE DURING EASTERN STANDARD TIME AT 1-800-523-2462 FROM 8AM - 5PM. FOR AFTER-HOURS, CALL EAST COAST: 1-866-836-1863 OR 1-800-407-4545 / MID-WEST: 1-888-308-8843 / WEST COAST: 1-888-419-2564. DO NOT LEAVE ANY PROBLEM UNRESOLVED. IF YOU MUST WAIT FOR THE FOLLOWING WORKDAY TO CALL B.E.A., LEAVE THE DOOR INOPERABLE UNTIL SATISFACTORY REPAIRS CAN BE MADE. NEVER SACRIFICE THE SAFE OPERATION OF THE AUTOMATIC DOOR OR GATE FOR AN INCOMPLETE SOLUTION. WEB: WWW.BEASENSORS.COM

**BEA**  
 We open up New Horizons  
 HALMA GROUP COMPANY  
 100 ENTERPRISE DRIVE  
 PITTSBURGH, PA 15275  
 PHONE: (412) 249-4100  
 FAX: (412) 249-4101  
 EMAIL: www.beasensors.com

**TITLE: DOROMATIC ASTRO-SWING WITH COMMANDER 1,2 SYSTEMS (LO21)**

SIZE: <b>A</b>	DRAWN BY: KJG	REV BY: KJG	PART NO: <b>80.0068.03</b>
	SCALE: NONE	DATE: 17 JUL 05	SHEET 1 OF 1

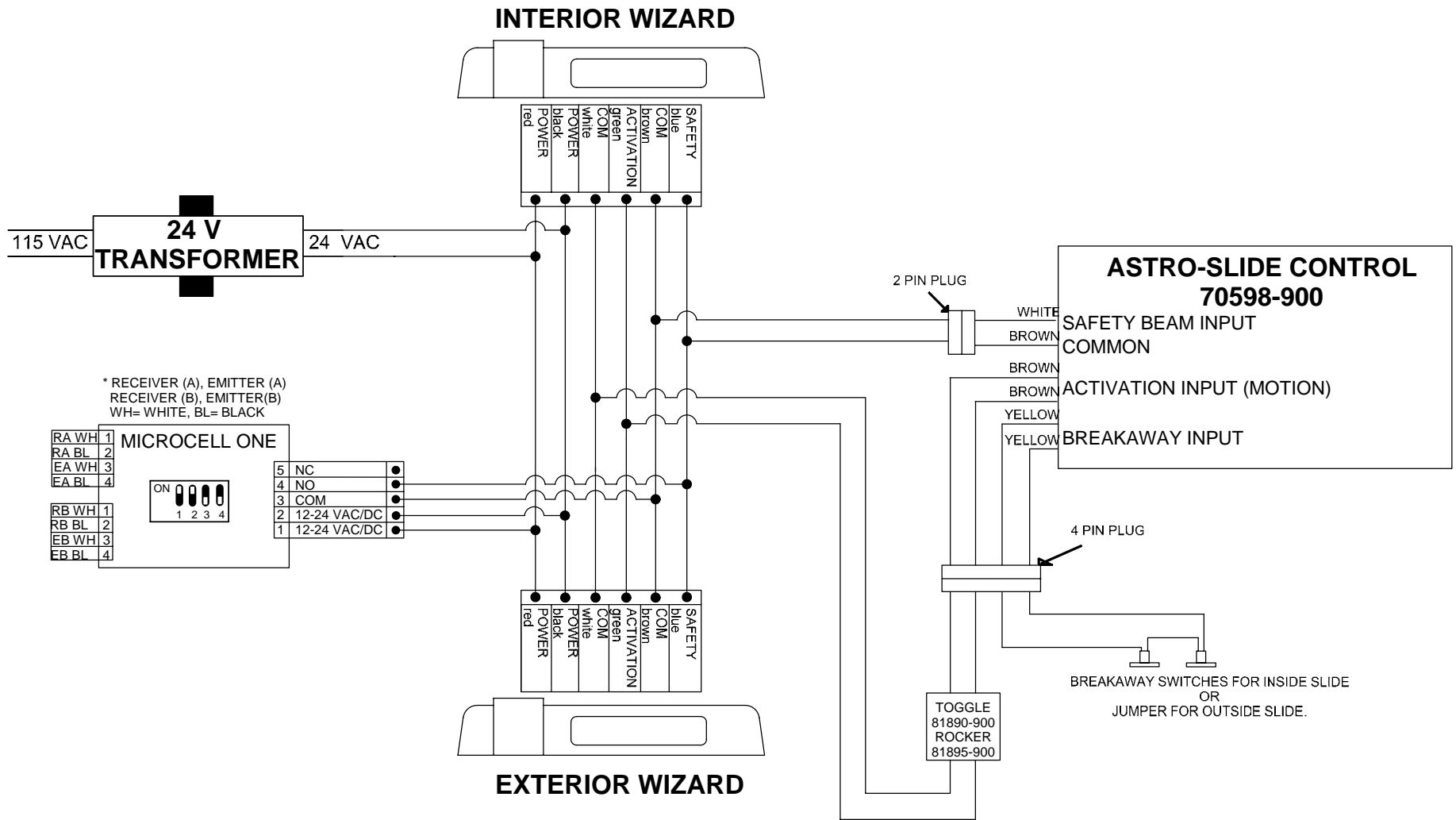

NOTES: 1) WIZARD WILL OPERATE ON THE 12 VAC FROM DOM SUPPLIED TRANSFORMER.

IF AFTER TROUBLESHOOTING A PROBLEM, A SATISFACTORY SOLUTION CANNOT BE ACHIEVED, PLEASE CALL B.E.A., INC. FOR FURTHER ASSISTANCE DURING EASTERN STANDARD TIME AT 1-800-523-2462 FROM 8AM - 5PM. FOR AFTER-HOURS, CALL EAST COAST: 1-866-836-1863 OR 1-800-407-4545 / MID-WEST: 1-888-308-8843 / WEST COAST: 1-888-419-2564. DO NOT LEAVE ANY PROBLEM UNRESOLVED. IF YOU MUST WAIT FOR THE FOLLOWING WORKDAY TO CALL B.E.A., LEAVE THE DOOR INOPERABLE UNTIL SATISFACTORY REPAIRS CAN BE MADE. NEVER SACRIFICE THE SAFE OPERATION OF THE AUTOMATIC DOOR OR GATE FOR AN INCOMPLETE SOLUTION. WEB: WWW.BEASENSORS.COM



100 ENTERPRISE DRIVE  
PITTSBURGH, PA 15275  
PHONE: (412) 249-4100  
FAX: (412) 249-4101  
EMAIL: www.beasensors.com

**TITLE: DOM ASTRO-SLIDE CONTROL WITH WIZARD SYSTEM**

SIZE: <b>A</b>	DRAWN BY: KJG	REV BY: KJG	PART NO: <b>80.0069.03</b>
	SCALE: NONE	DATE: 17 JUL 05	

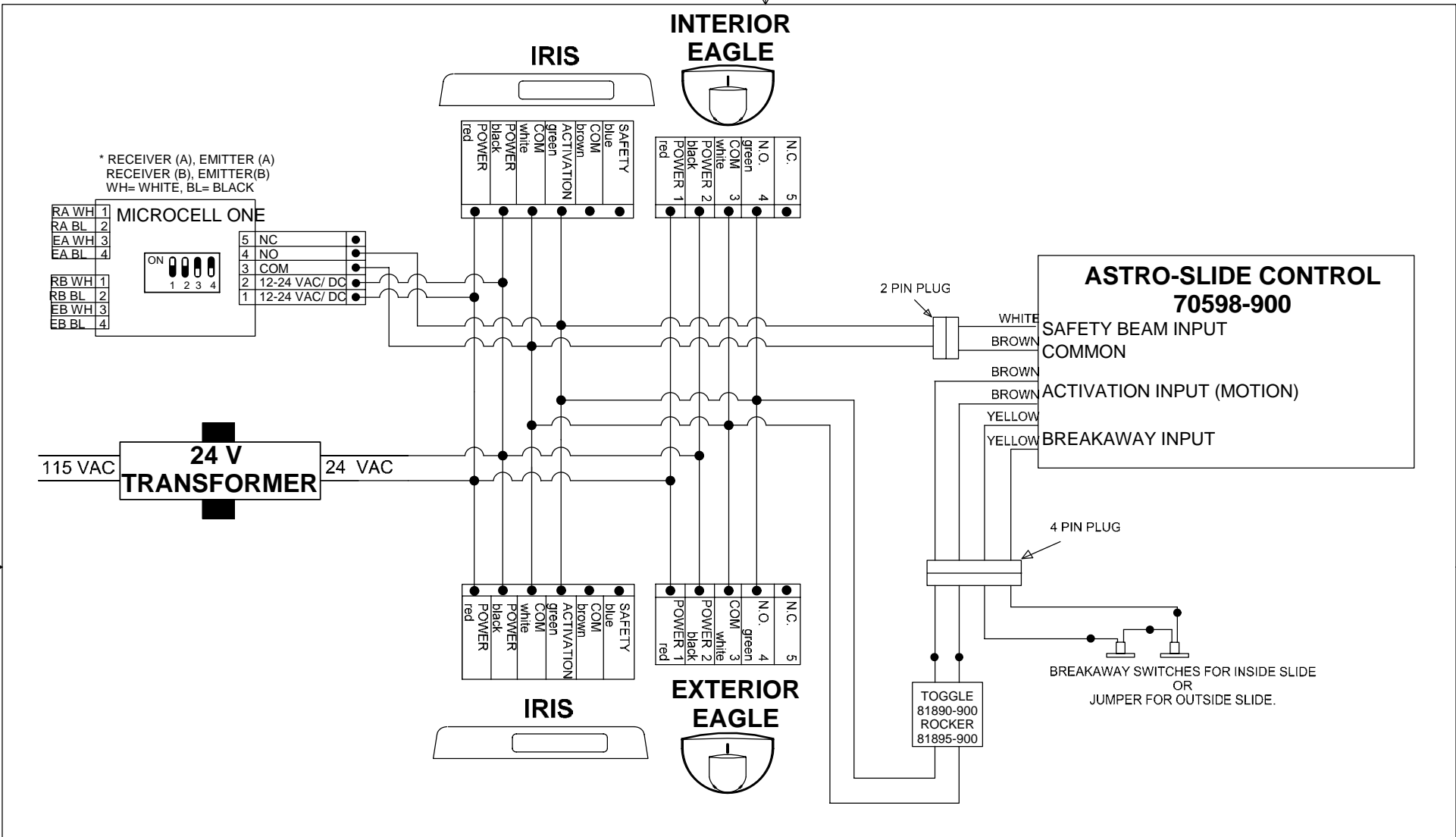

NOTES: 1) EAGLES, IRISES, AND MICROCELL 1 WILL OPERATE ON THE 12 VAC FROM DOM SUPPLIED TRANSFORMER.

IF AFTER TROUBLESHOOTING A PROBLEM, A SATISFACTORY SOLUTION CANNOT BE ACHIEVED, PLEASE CALL B.E.A., INC. FOR FURTHER ASSISTANCE DURING EASTERN STANDARD TIME AT 1-800-523-2462 FROM 8AM - 5PM. FOR AFTER-HOURS, CALL EAST COAST: 1-866-836-1863 OR 1-800-407-4545 / MID-WEST: 1-888-308-8843 / WEST COAST: 1-888-419-2564. DO NOT LEAVE ANY PROBLEM UNRESOLVED. IF YOU MUST WAIT FOR THE FOLLOWING WORKDAY TO CALL B.E.A., LEAVE THE DOOR INOPERABLE UNTIL SATISFACTORY REPAIRS CAN BE MADE. NEVER SACRIFICE THE SAFE OPERATION OF THE AUTOMATIC DOOR OR GATE FOR AN INCOMPLETE SOLUTION. WEB: WWW.BEASENSORS.COM



100 ENTERPRISE DRIVE  
PITTSBURGH, PA 15275  
PHONE: (412) 249-4100  
FAX: (412) 249-4101  
EMAIL: www.beasensors.com

**TITLE: DOM ASTRO-SLIDE CONTROL WITH EAGLES, IRIS, MICROCELL 1**

SIZE: <b>A</b>	DRAWN BY: KJG	REV BY: KJG	PART NO: <b>80.0070.03</b>
	SCALE: NONE	DATE: 20 JUL 05	SHEET 1 OF 1

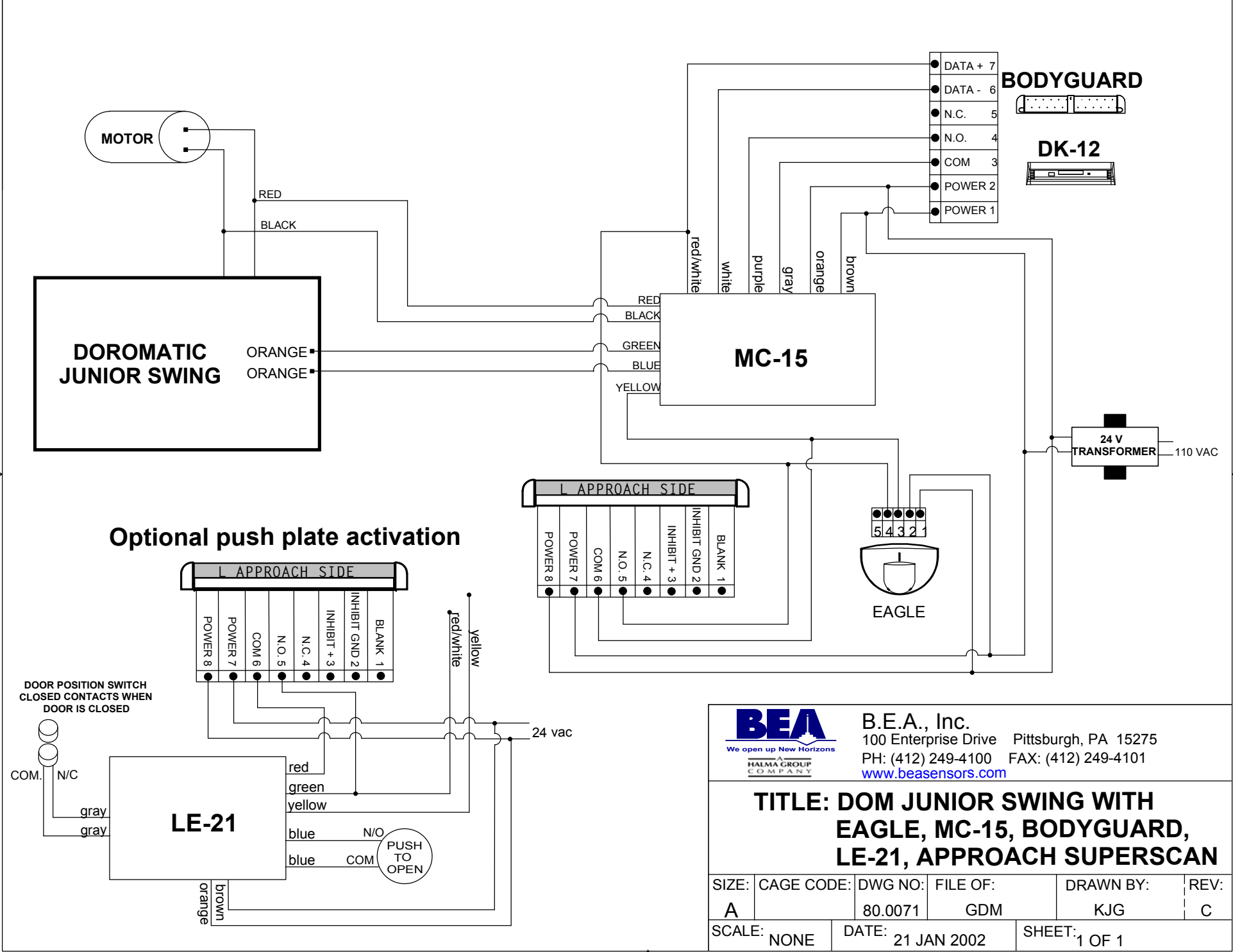

**Optional push plate activation**

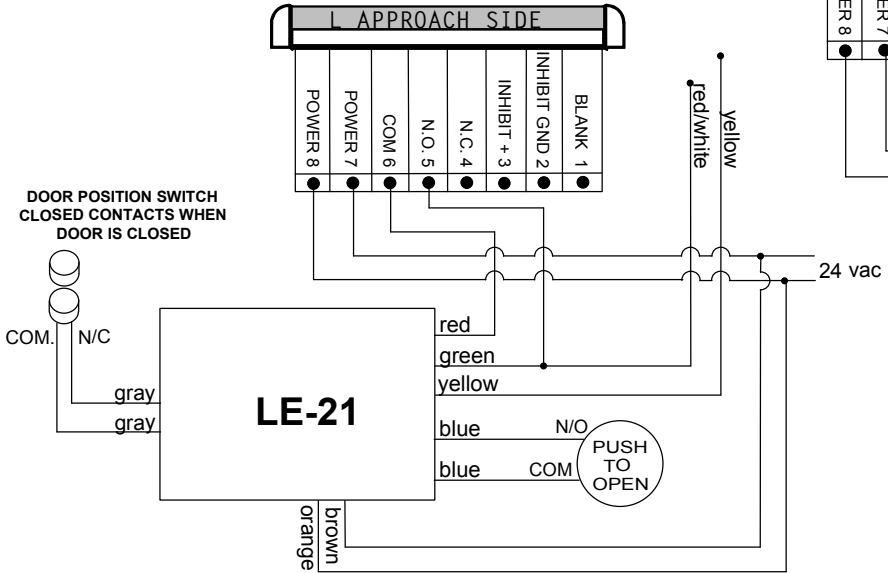

**B.E.A., Inc.**  
 100 Enterprise Drive Pittsburgh, PA 15275  
 PH: (412) 249-4100 FAX: (412) 249-4101  
[www.beasensors.com](http://www.beasensors.com)

**TITLE: DOM JUNIOR SWING WITH EAGLE, MC-15, BODYGUARD, LE-21, APPROACH SUPERSCAN**

SIZE:	CAGE CODE:	DWG NO:	FILE OF:	DRAWN BY:	REV:
A		80.0071	GDM	KJG	C
SCALE: NONE		DATE: 21 JAN 2002		SHEET: 1 OF 1	

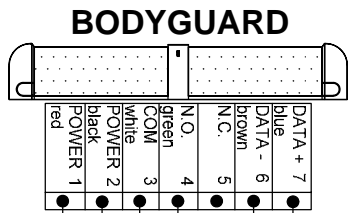

**BODYGUARD**

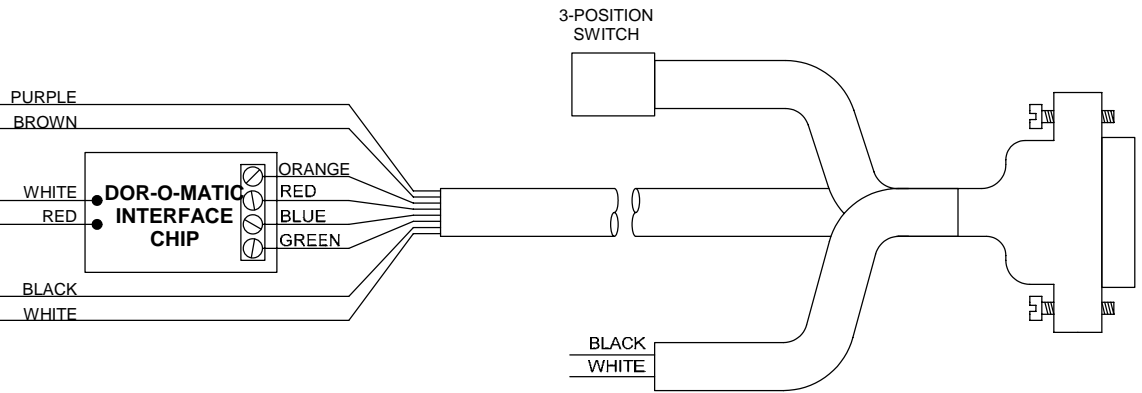

**DOR-O-MATIC  
SWING DOOR  
CONTROL BOX**

15-PIN  
CONNECTOR

TRIM AND TAPE BLACK  
AND WHITE WIRES  
ON THIS CABLE ONLY

- NOTES: 1) CONNECT DOR-O-MATIC CABLE TO DOR-O-MATIC INTERFACE CHIP INSIDE B.E.A. BODYGUARD/ DK-12 AND 7-PIN CONNECTOR OF BODYGUARD OR DK-12.  
 2) SET FUNCTION SWITCH TO "E" PREFERRED IF AVAILABLE, OR FUNCTIONS 1-2.  
 3) BEAMS OR SWING SIDE SUPERSCAN MUST BE USED TO ENSURE COMPLIANCE TO ANSI 156.10

IF AFTER TROUBLESHOOTING A PROBLEM, A SATISFACTORY SOLUTION CANNOT BE ACHIEVED, PLEASE CALL B.E.A., INC. FOR FURTHER ASSISTANCE DURING EASTERN STANDARD TIME AT 1-800-523-2462 FROM 8AM - 5PM. FOR AFTER-HOURS, CALL EAST COAST: 1-866-836-1863 OR 1-800-407-4545 / MID-WEST: 1-888-308-8843 / WEST COAST: 1-888-419-2564. DO NOT LEAVE ANY PROBLEM UNRESOLVED. IF YOU MUST WAIT FOR THE FOLLOWING WORKDAY TO CALL B.E.A., LEAVE THE DOOR INOPERABLE UNTIL SATISFACTORY REPAIRS CAN BE MADE. NEVER SACRIFICE THE SAFE OPERATION OF THE AUTOMATIC DOOR OR GATE FOR AN INCOMPLETE SOLUTION. WEB: WWW.BEASENSORS.COM

**BEA**  
 We open up New Horizons  
 HALMA GROUP  
 COMPANY

100 ENTERPRISE DRIVE  
 PITTSBURGH, PA 15275  
 PHONE: (412) 249-4100  
 FAX: (412) 249-4101  
 EMAIL: www.beasensors.com

**TITLE: DOROMATIC ASTRO-SWING WITH  
BODYGUARD, INTERFACE CHIP**

SIZE: <b>A</b>	DRAWN BY: KJG	REV BY: JDC	PART NO: <b>80.0072.04</b>
	SCALE: NONE	DATE: 20 MARCH 2006	SHEET 1 OF 1

# DOR-O-MATIC INTERFACE WITH SAFETY BEAMS, NO SUPERSCANS

## BODYGUARD/ DK-12

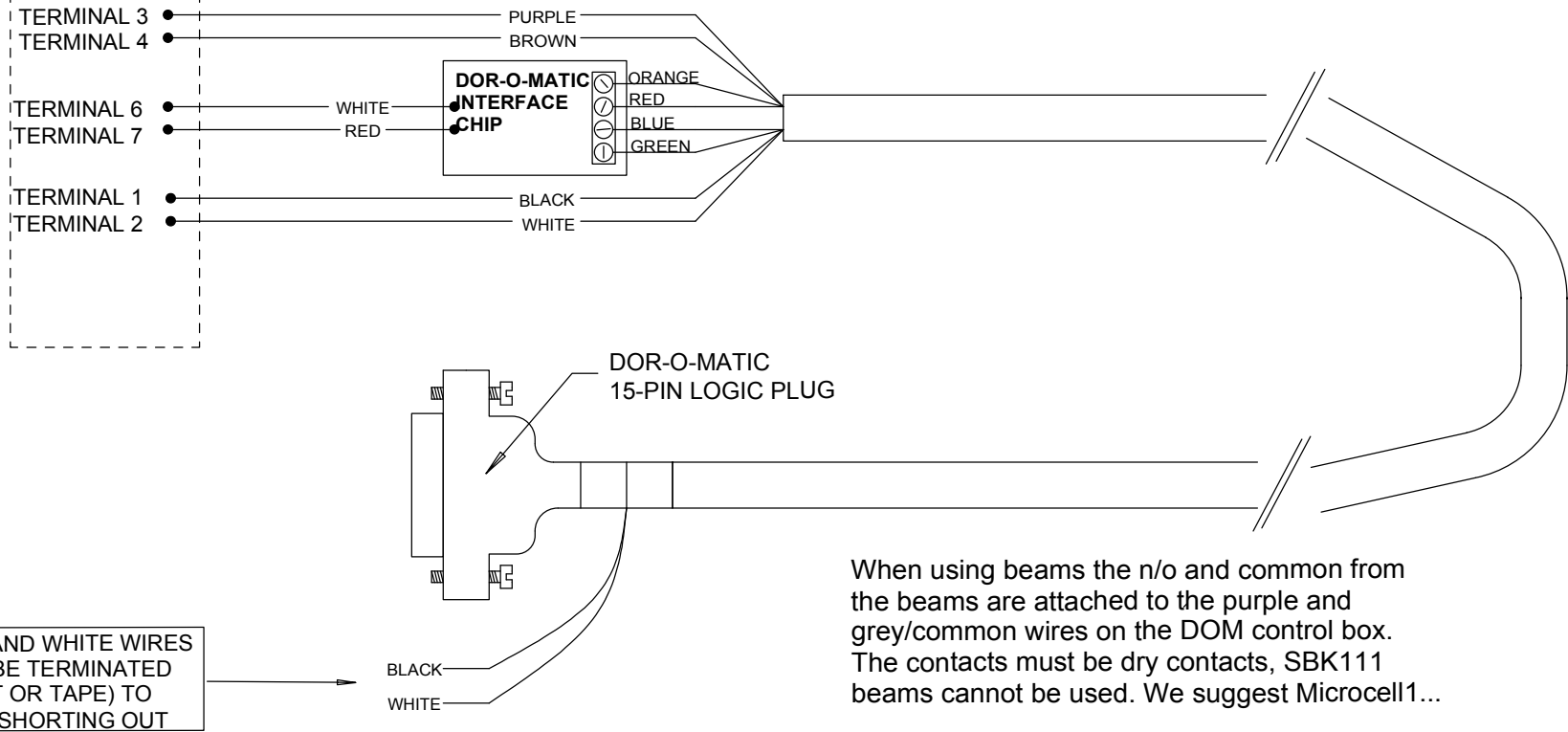

When using beams the n/o and common from the beams are attached to the purple and grey/common wires on the DOM control box. The contacts must be dry contacts, SBK111 beams cannot be used. We suggest Microcell1...

CONNECT DOR-O-MATIC CABLE TO DOR-O-MATIC INTERFACE CHIP INSIDE B.E.A. BODYGUARD/ DK-12 AND 7-PIN CONNECTOR OF BODYGUARD OR DK-12

		<b>B.E.A., Inc.</b> 100 Enterprise Drive Pittsburgh, PA 15275 PH: (412) 249-4100 FAX: (412) 249-4101 <a href="http://www.beasensors.com">www.beasensors.com</a>			
Title: DOR-O-MATIC INTERFACE WITH SAFETY BEAMS					
Part Number: 77679-900 HARNESS					
<b>SIZE</b> <b>A</b>	<b>CAGE CODE</b>	<b>DWG NO</b> 80.0073	<b>FILE OF:</b> GDM	<b>DRAWN BY:</b> KJG	<b>REV</b> B
<b>SCALE</b> None		<b>Date:</b> 11 NOV 2000		<b>SHEET</b> 1 of 1	

TOP VIEW OF HEADER AND DOOR AT 90 DEGREES

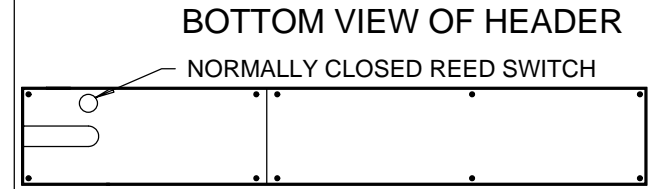
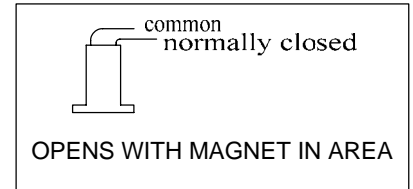
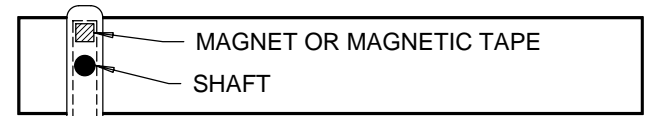
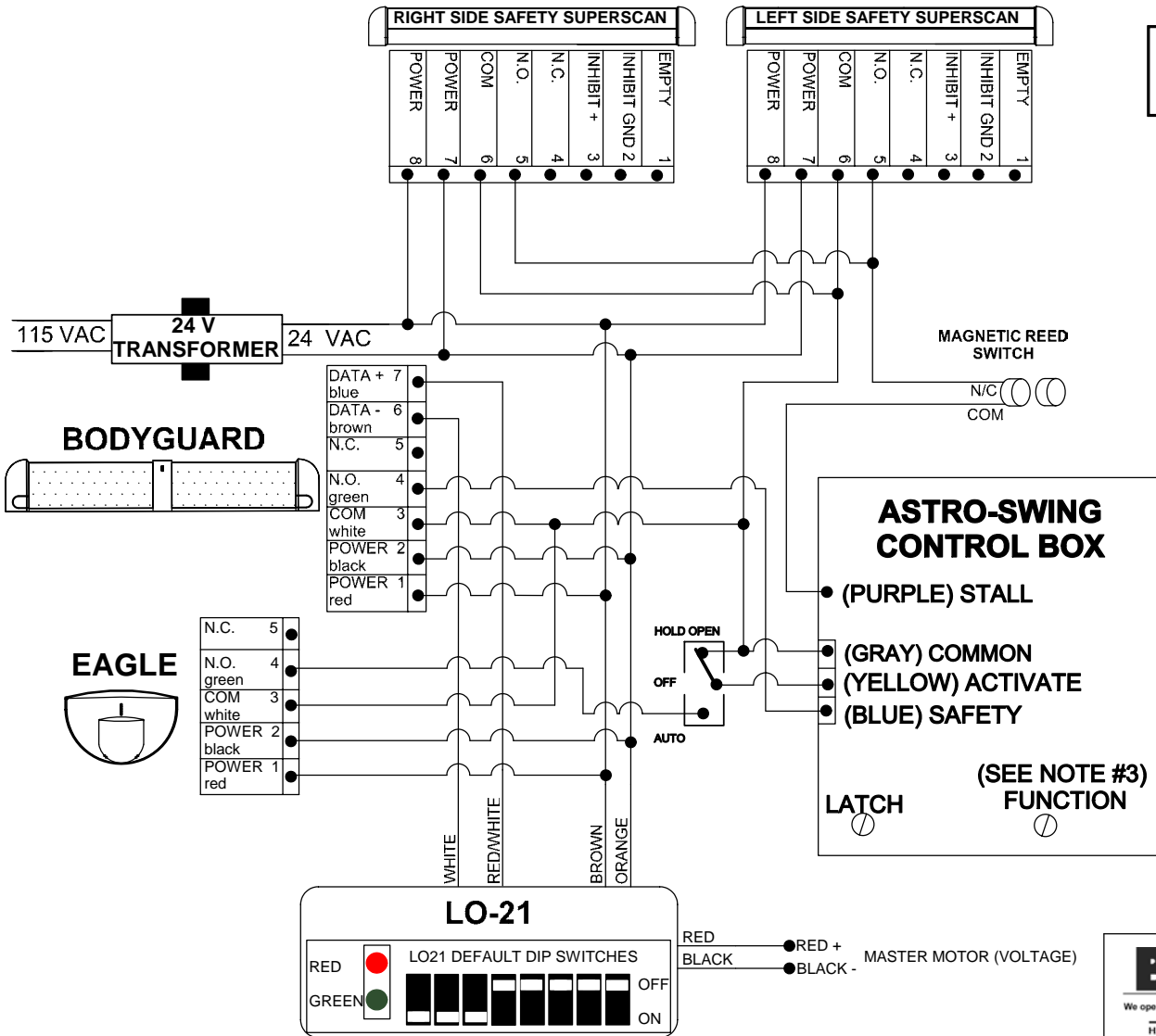

- NOTES: 1) POSITION DOOR AT 90 DEGREES, DRAW LINES ON BOTTOM OF HEADER TO INDICATE DOOR WHEN OPEN.  
 2) REED SWITCH MUST BE ACTIVATED BY MAGNET FROM 70 DEGREES THRU 90 DEGREES. THIS SWITCH WILL OPEN THE SUPERSCAN CIRCUIT TO ELIMINATE GUIDE RAIL AND WALL INTERFERENCE.  
 3) ON PUSH OR INSWING SURFACE APPLIED HEADERS WITH VISABLE ARMS, USE SAME REED SWITCH IN HEADER, WITH MAGNET POSITION ON TOP OF HEADER.

IF AFTER TROUBLESHOOTING A PROBLEM, A SATISFACTORY SOLUTION CANNOT BE ACHIEVED, PLEASE CALL B.E.A., INC. FOR FURTHER ASSISTANCE DURING EASTERN STANDARD TIME AT 1-800-523-2462 FROM 8AM - 5PM. FOR AFTER-HOURS, CALL EAST COAST: 1-866-836-1863 OR 1-800-407-4545 / MID-WEST: 1-888-308-8843 / WEST COAST: 1-888-419-2564. DO NOT LEAVE ANY PROBLEM UNRESOLVED. IF YOU MUST WAIT FOR THE FOLLOWING WORKDAY TO CALL B.E.A., LEAVE THE DOOR INOPERABLE UNTIL SATISFACTORY REPAIRS CAN BE MADE. NEVER SACRIFICE THE SAFE OPERATION OF THE AUTOMATIC DOOR OR GATE FOR AN INCOMPLETE SOLUTION. WEB: WWW.BEASENSORS.COM

**BEA** 100 ENTERPRISE DRIVE  
 PITTSBURGH, PA 15275  
 PHONE: (412) 249-4100  
 FAX: (412) 249-4101  
 EMAIL: www.beasensors.com

**TITLE: DOROMATIC ASTROSWING WITH SAFETY SIDE SUPERSCAN CUT-OFF SWITCH**

SIZE: <b>A</b>	DRAWN BY: KJG	REV BY: KJG	PART NO: <b>80.0074.03</b>
	SCALE: NONE	DATE: 07 AUG 05	SHEET 1 OF 1

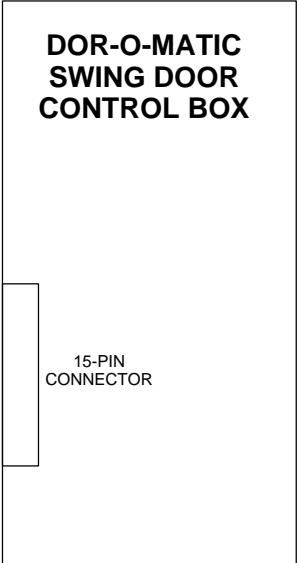
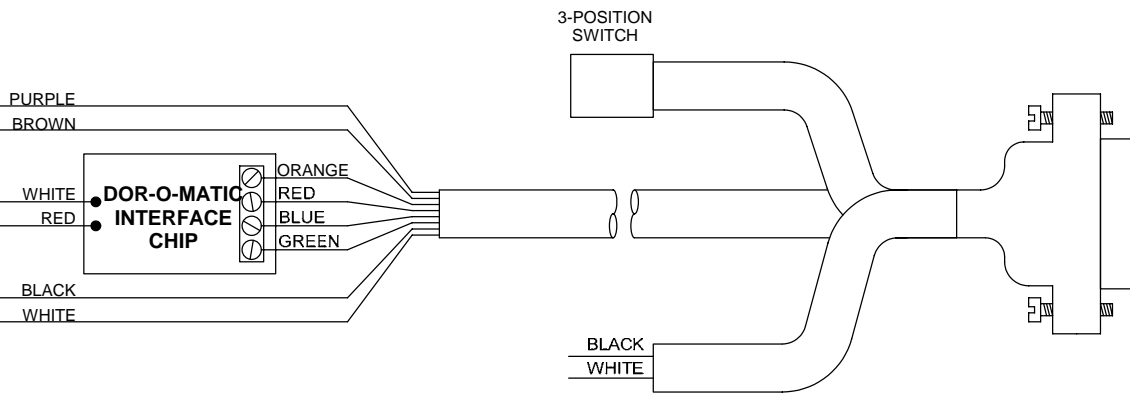
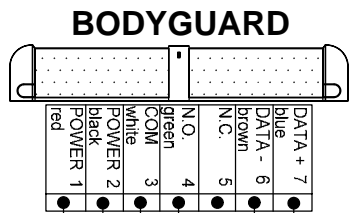

TRIM AND TAPE BLACK AND WHITE WIRES ON THIS CABLE ONLY

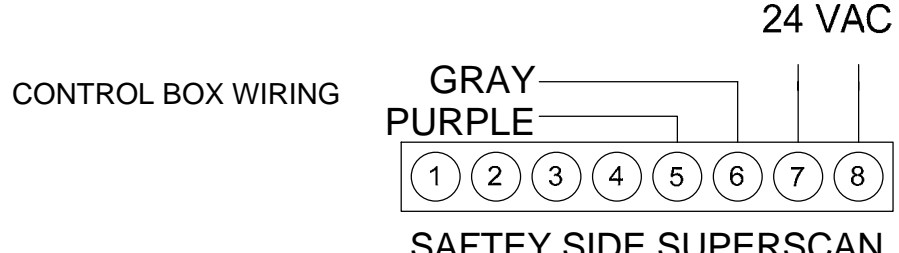
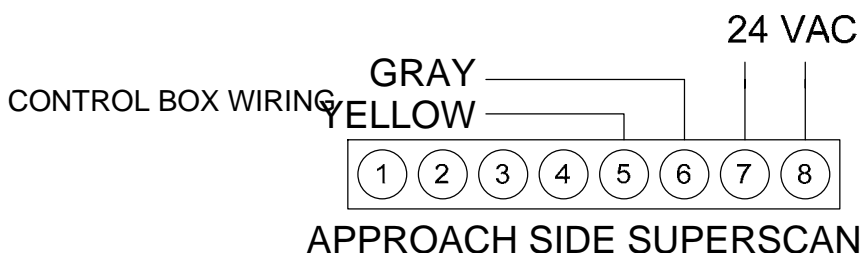

NOTES: 1) CONNECT DOR-O-MATIC CABLE TO DOR-O-MATIC INTERFACE CHIP INSIDE B.E.A. BODYGUARD AND 7-PIN CONNECTOR OF BODYGUARD  
 2) SET CONTROL BOX FUNCTION TO '5' or '6'. 'E' FUNCTION PREFERRED IF AVAILABLE.

IF AFTER TROUBLESHOOTING A PROBLEM, A SATISFACTORY SOLUTION CANNOT BE ACHIEVED, PLEASE CALL B.E.A., INC. FOR FURTHER ASSISTANCE DURING EASTERN STANDARD TIME AT 1-800-523-2462 FROM 8AM - 5PM. FOR AFTER-HOURS, CALL EAST COAST: 1-866-836-1863 OR 1-800-407-4545 / MID-WEST: 1-888-308-8843 / WEST COAST: 1-888-419-2564. DO NOT LEAVE ANY PROBLEM UNRESOLVED. IF YOU MUST WAIT FOR THE FOLLOWING WORKDAY TO CALL B.E.A., LEAVE THE DOOR INOPERABLE UNTIL SATISFACTORY REPAIRS CAN BE MADE. NEVER SACRIFICE THE SAFE OPERATION OF THE AUTOMATIC DOOR OR GATE FOR AN INCOMPLETE SOLUTION. WEB: WWW.BEASENSORS.COM

**BEA**  
 We open up New Horizons  
 HALMA GROUP COMPANY  
 100 ENTERPRISE DRIVE  
 PITTSBURGH, PA 15275  
 PHONE: (412) 249-4100  
 FAX: (412) 249-4101  
 EMAIL: www.beasensors.com

**TITLE: DOR-O-MATIC INTERFACE CHIP/ CABLE WITH BODYGUARD, SUPERSCANS**  
**Part Number: 77679-900 HARNESS**

SIZE: <b>A</b>	DRAWN BY: KJG	REV BY: JDC	PART NO: <b>80.0076.03</b>
	SCALE: NONE	DATE: 20 MARCH 2006	SHEET 1 OF 1



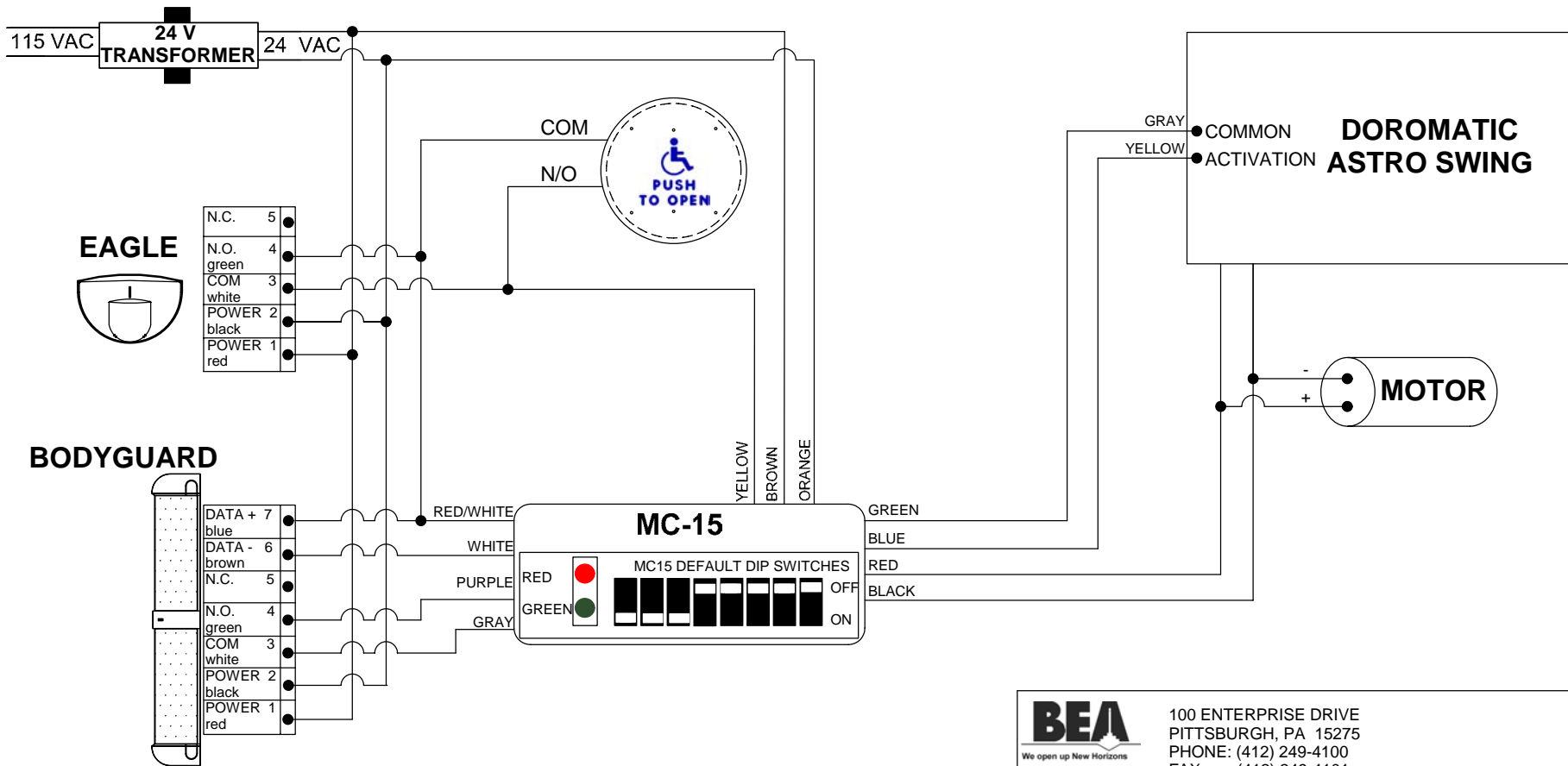

NOTES: 1) APPLICATION WILL REQUIRE THE ADDITION OF SAFETY SIDE SUPERSCAN AND SECONDARY REACTIVATION TO MEET ANSI COMPLIANCE

IF AFTER TROUBLESHOOTING A PROBLEM, A SATISFACTORY SOLUTION CANNOT BE ACHIEVED, PLEASE CALL B.E.A., INC. FOR FURTHER ASSISTANCE DURING EASTERN STANDARD TIME AT 1-800-523-2462 FROM 8AM - 5PM. FOR AFTER-HOURS, CALL EAST COAST: 1-866-836-1863 OR 1-800-407-4545 / MID-WEST: 1-888-308-8843 / WEST COAST: 1-888-419-2564. DO NOT LEAVE ANY PROBLEM UNRESOLVED. IF YOU MUST WAIT FOR THE FOLLOWING WORKDAY TO CALL B.E.A., LEAVE THE DOOR INOPERABLE UNTIL SATISFACTORY REPAIRS CAN BE MADE. NEVER SACRIFICE THE SAFE OPERATION OF THE AUTOMATIC DOOR OR GATE FOR AN INCOMPLETE SOLUTION. WEB: WWW.BEASENSORS.COM

**BEA**  
 We open up New Horizons  
 A HALMA GROUP COMPANY  
 100 ENTERPRISE DRIVE  
 PITTSBURGH, PA 15275  
 PHONE: (412) 249-4100  
 FAX: (412) 249-4101  
 EMAIL: www.beasensors.com

**TITLE: DOM ASTRO-SWING WITH EAGLE, MC-15, BODYGUARD, PUSH PLATE**

SIZE: <b>A</b>	DRAWN BY: KJG	REV BY: KJG	PART NO: <b>80.0077.02</b>
	SCALE: NONE	DATE: 07 AUG 05	SHEET 1 OF 1

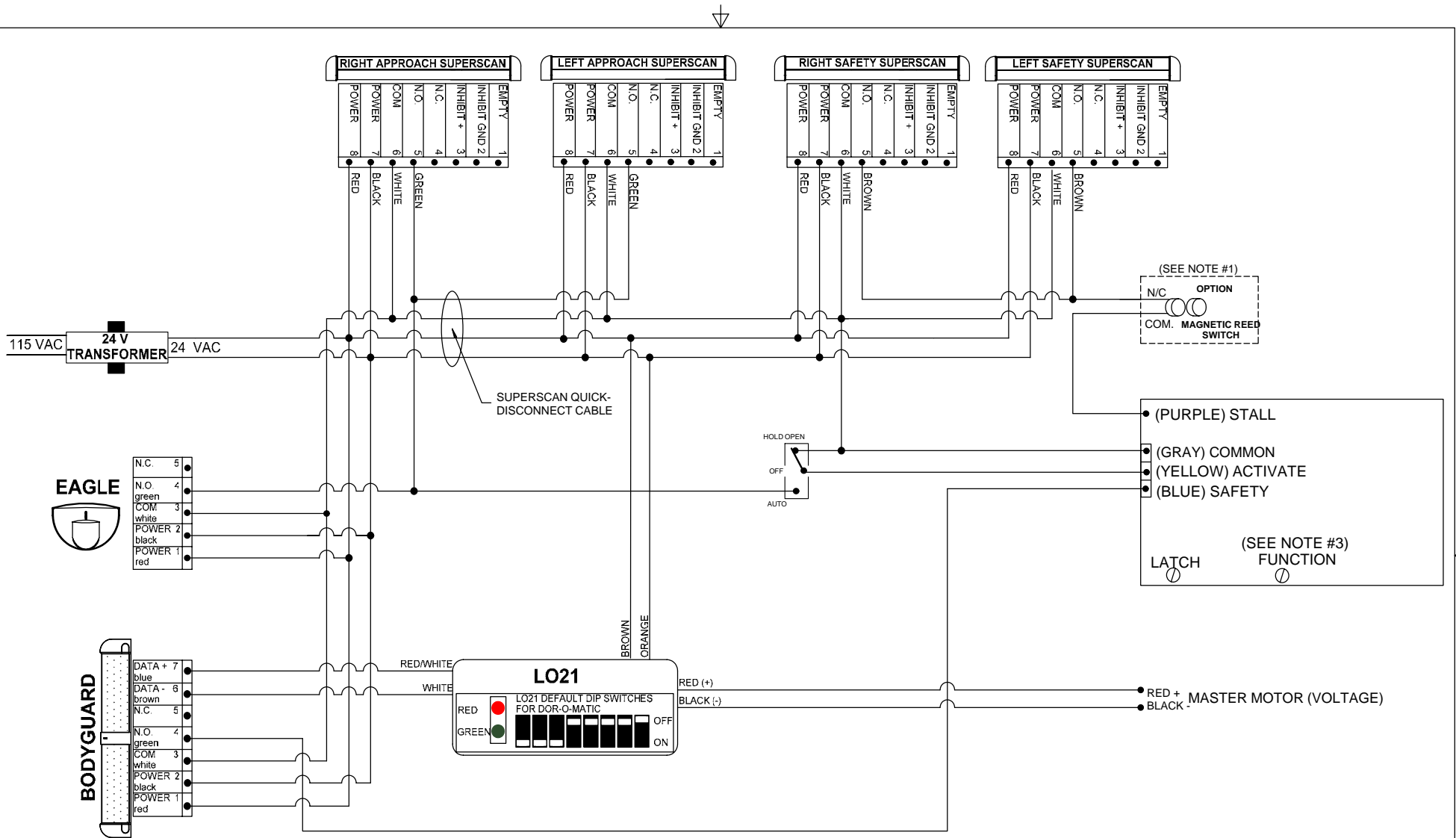

- NOTES: 1 ) THE MAGNETIC REED SWITCH SHALL OPEN AT APPROX. 65-70 DEGREES TO INHIBIT THE SWING SIDE SUPERSCANS AND SHALL STAY OPEN UNTIL CLOSING CYCLE OCCURS AND THE SWITCH MAKES AT 65-70 DEGREES.  
 2 ) LO21 DIP SWITCHES: 1-5 LOCKOUT TIME WILL VARY, #6-8, (NOT USED).  
 3 ) IF USING A MAGNETIC REED SWITCH TO INHIBIT SWING SIDE SUPERSCANS, SET CONTROL FUNCTION DIAL TO 6. IF NOT USING INHIBIT SWITCH, SET CONTROL FUNCTION DIAL TO 5.  
 4 ) IF BODYGUARD HAS DOM INTERFACE CIRCUIT BOARD, IT MUST BE REMOVED.

IF AFTER TROUBLESHOOTING A PROBLEM, A SATISFACTORY SOLUTION CANNOT BE ACHIEVED, PLEASE CALL B.E.A., INC. FOR FURTHER ASSISTANCE DURING EASTERN STANDARD TIME AT 1-800-523-2462 FROM 8AM - 5PM. FOR AFTER-HOURS, CALL EAST COAST: 1-866-836-1863 OR 1-800-407-4545 / MID-WEST: 1-888-308-8843 / WEST COAST: 1-888-419-2564. DO NOT LEAVE ANY PROBLEM UNRESOLVED. IF YOU MUST WAIT FOR THE FOLLOWING WORKDAY TO CALL B.E.A., LEAVE THE DOOR INOPERABLE UNTIL SATISFACTORY REPAIRS CAN BE MADE. NEVER SACRIFICE THE SAFE OPERATION OF THE AUTOMATIC DOOR OR GATE FOR AN INCOMPLETE SOLUTION. WEB: WWW.BEASENSORS.COM

		100 ENTERPRISE DRIVE PITTSBURGH, PA 15275 PHONE: (412) 249-4100 FAX: (412) 249-4101 EMAIL: www.beasensors.com	
		<b>TITLE: DOROMATIC ASTRO-SWING WITH PARALLAX 2 SYSTEM (LO21) Q-DISCONNECT ON APPROACH SIDE</b>	
SIZE: B	DRAWN BY: KJG	REV BY: KJG	PART NO: 80.0078.02
SCALE: NONE	DATE: 09 AUG 05	SHEET: 1 OF 1	

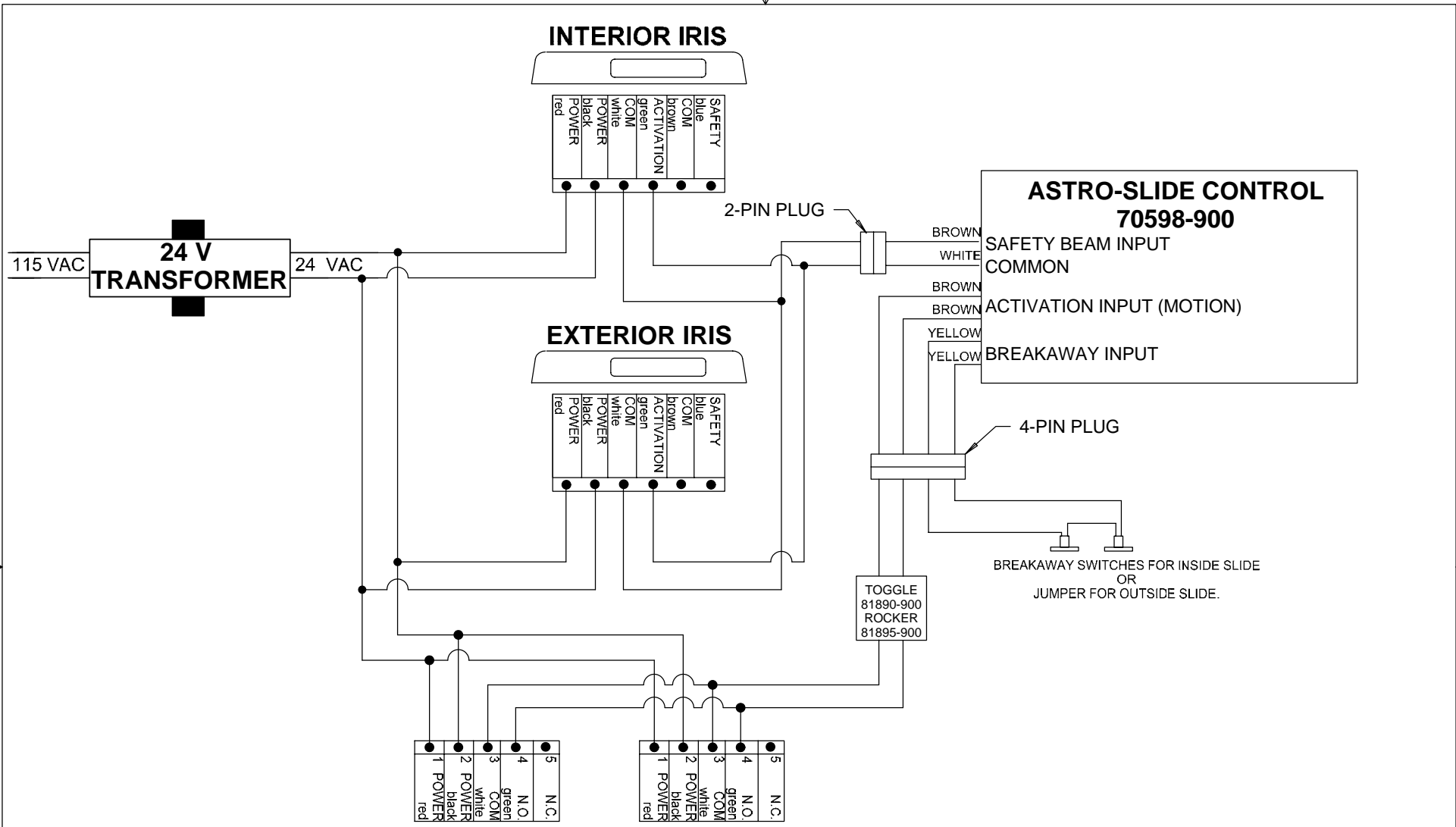

INTERIOR EAGLE      EXTERIOR EAGLE



**BEA**  
We open up New Horizons  
 HALMA GROUP COMPANY

100 ENTERPRISE DRIVE  
 PITTSBURGH, PA 15275  
 PHONE: (412) 249-4100  
 FAX: (412) 249-4101  
 EMAIL: [www.beasensors.com](http://www.beasensors.com)

**TITLE: DOM ASTRO-SLIDE CONTROL WITH EAGLES, IRISES**

IF AFTER TROUBLESHOOTING A PROBLEM, A SATISFACTORY SOLUTION CANNOT BE ACHIEVED, PLEASE CALL B.E.A., INC. FOR FURTHER ASSISTANCE DURING EASTERN STANDARD TIME AT 1-800-523-2462 FROM 8AM - 5PM. FOR AFTER-HOURS, CALL EAST COAST: 1-866-836-1863 OR 1-800-407-4545 / MID-WEST: 1-888-308-8843 / WEST COAST: 1-888-419-2564. DO NOT LEAVE ANY PROBLEM UNRESOLVED. IF YOU MUST WAIT FOR THE FOLLOWING WORKDAY TO CALL B.E.A., LEAVE THE DOOR INOPERABLE UNTIL SATISFACTORY REPAIRS CAN BE MADE. NEVER SACRIFICE THE SAFE OPERATION OF THE AUTOMATIC DOOR OR GATE FOR AN INCOMPLETE SOLUTION. WEB: [WWW.BEASENSORS.COM](http://WWW.BEASENSORS.COM)

SIZE: <b>A</b>	DRAWN BY: KJG	REV BY: KJG	PART NO: <b>80.0079.03</b>
	SCALE: NONE	DATE: 13 AUG 05	SHEET 1 OF 1

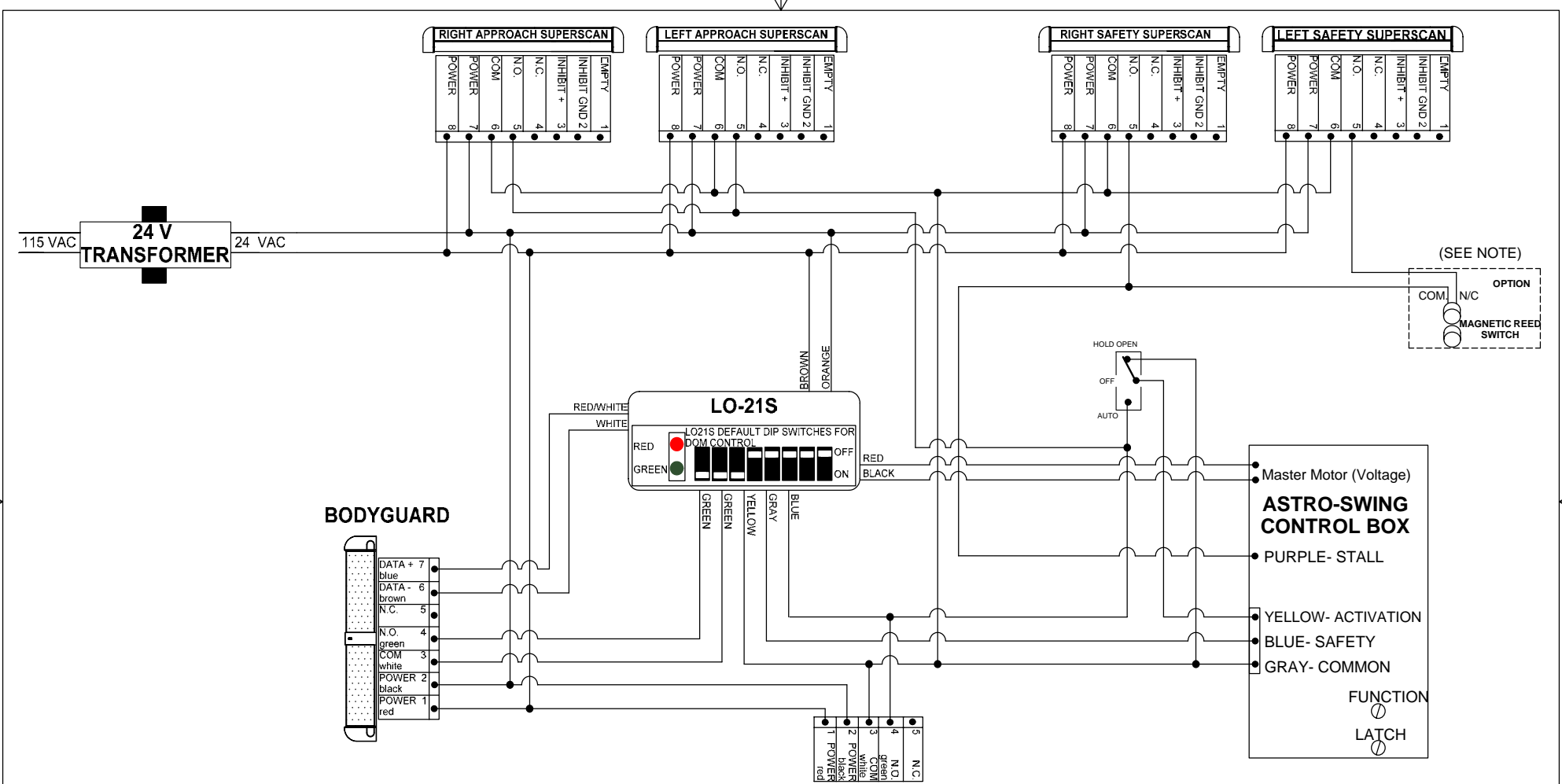

- NOTES: 1) ASTRO-SWING CONTROL BOX MUST BE SET TO FUNCTION 5,6.  
 2) IF BODYGUARD HAS DOM INTERFACE CIRCUIT BOARD, IT MUST BE REMOVED  
 3) THE MAGNETIC REED SWITCH SHALL OPEN AT APPROX. 65-70 DEGREES TO INHIBIT THE SWING SIDE SUPERSCANS AND SHALL STAY OPEN UNTIL CLOSING CYCLE OCCURS AND THE SWITCH MAKES AT 65-70 DEGREES.  
 4) IF USING A MAGNETIC REED SWITCH TO INHIBIT SWING SIDE SUPERSCANS, SET CONTROL FUNCTION DIAL TO 6. IF NOT USING INHIBIT SWITCH, SET CONTROL FUNCTION DIAL TO 5.

IF AFTER TROUBLESHOOTING A PROBLEM, A SATISFACTORY SOLUTION CANNOT BE ACHIEVED, PLEASE CALL B.E.A., INC. FOR FURTHER ASSISTANCE DURING EASTERN STANDARD TIME AT 1-800-523-2462 FROM 8AM - 5PM. FOR AFTER-HOURS, CALL EAST COAST: 1-866-836-1863 OR 1-800-407-4545 / MID-WEST: 1-888-308-8843 / WEST COAST: 1-888-419-2564. DO NOT LEAVE ANY PROBLEM UNRESOLVED. IF YOU MUST WAIT FOR THE FOLLOWING WORKDAY TO CALL B.E.A., LEAVE THE DOOR INOPERABLE UNTIL SATISFACTORY REPAIRS CAN BE MADE. NEVER SACRIFICE THE SAFE OPERATION OF THE AUTOMATIC DOOR OR GATE FOR AN INCOMPLETE SOLUTION.WEB: WWW.BEASENSORS.COM



		100 ENTERPRISE DRIVE PITTSBURGH, PA 15275 PHONE: (412) 249-4100 FAX: (412) 249-4101 EMAIL: www.beasensors.com	
<b>TITLE: DOROMATIC ASTRO-SWING WITH PARALLAX 2 SYSTEM AND LO21S</b>			
SIZE: <b>B</b>	DRAWN BY: KJG	REV BY: KJG	PART NO: <b>80.0080.04</b>
	SCALE: NONE	DATE: 14AUG05	SHEET 1 OF 1

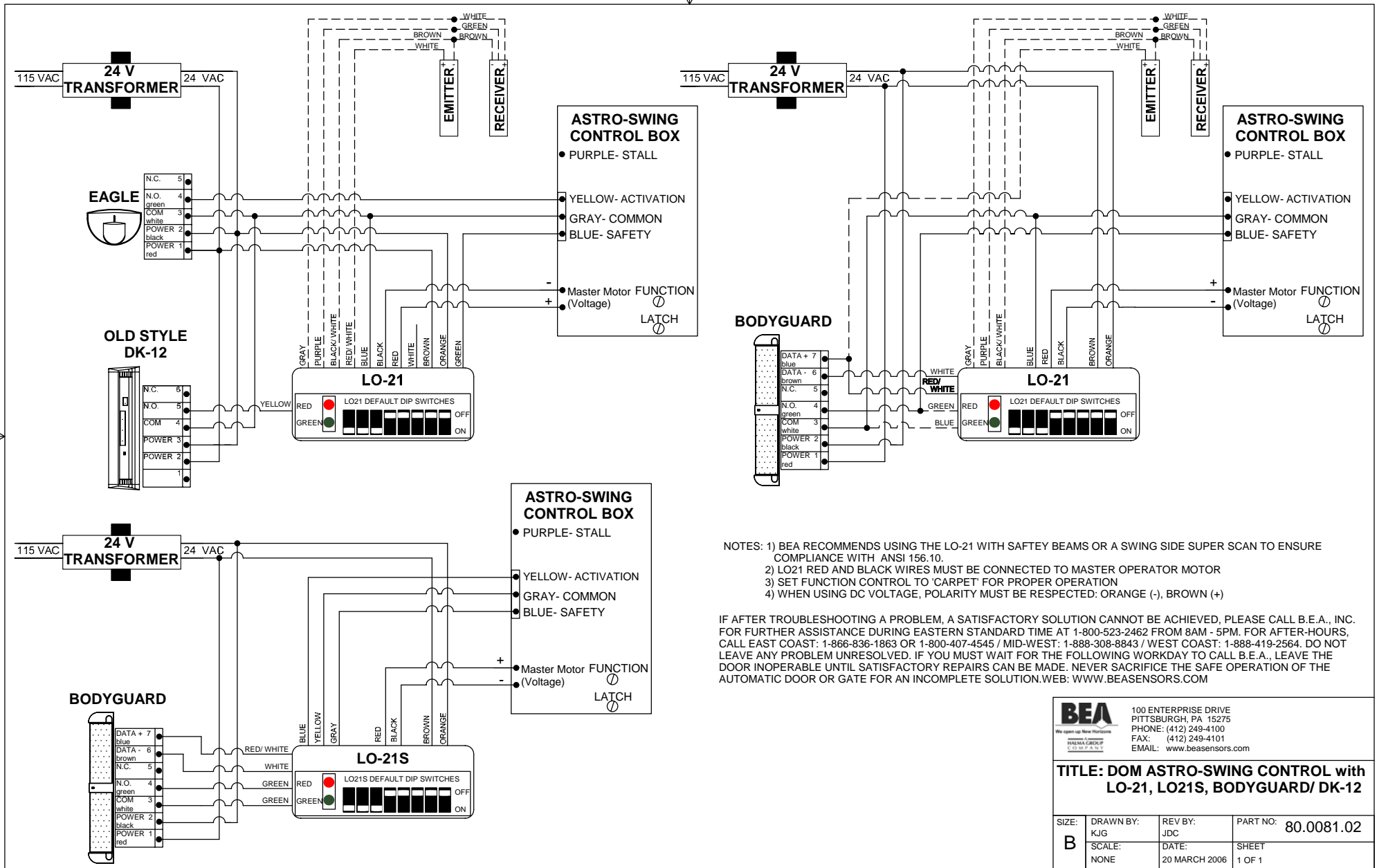

- NOTES: 1) BEA RECOMMENDS USING THE LO-21 WITH SAFETY BEAMS OR A SWING SIDE SUPER SCAN TO ENSURE COMPLIANCE WITH ANSI 156.10.  
 2) LO21 RED AND BLACK WIRES MUST BE CONNECTED TO MASTER OPERATOR MOTOR  
 3) SET FUNCTION CONTROL TO 'CARPET' FOR PROPER OPERATION  
 4) WHEN USING DC VOLTAGE, POLARITY MUST BE RESPECTED: ORANGE (-), BROWN (+)

IF AFTER TROUBLESHOOTING A PROBLEM, A SATISFACTORY SOLUTION CANNOT BE ACHIEVED, PLEASE CALL B.E.A., INC. FOR FURTHER ASSISTANCE DURING EASTERN STANDARD TIME AT 1-800-523-2462 FROM 8AM - 5PM. FOR AFTER-HOURS, CALL EAST COAST: 1-866-836-1863 OR 1-800-407-4545 / MID-WEST: 1-888-308-8843 / WEST COAST: 1-888-419-2564. DO NOT LEAVE ANY PROBLEM UNRESOLVED. IF YOU MUST WAIT FOR THE FOLLOWING WORKDAY TO CALL B.E.A., LEAVE THE DOOR INOPERABLE UNTIL SATISFACTORY REPAIRS CAN BE MADE. NEVER SACRIFICE THE SAFE OPERATION OF THE AUTOMATIC DOOR OR GATE FOR AN INCOMPLETE SOLUTION. WEB: WWW.BEASENSORS.COM

		100 ENTERPRISE DRIVE PITTSBURGH, PA 15275 PHONE: (412) 249-4100 FAX: (412) 249-4101 EMAIL: www.beasensors.com	
<b>TITLE: DOM ASTRO-SWING CONTROL with          LO-21, LO21S, BODYGUARD/ DK-12</b>			
SIZE:	DRAWN BY:	REV BY:	PART NO:
<b>B</b>	KJG	JDC	<b>80.0081.02</b>
SCALE:	DATE:	SHEET:	
NONE	20 MARCH 2006	1 OF 1	

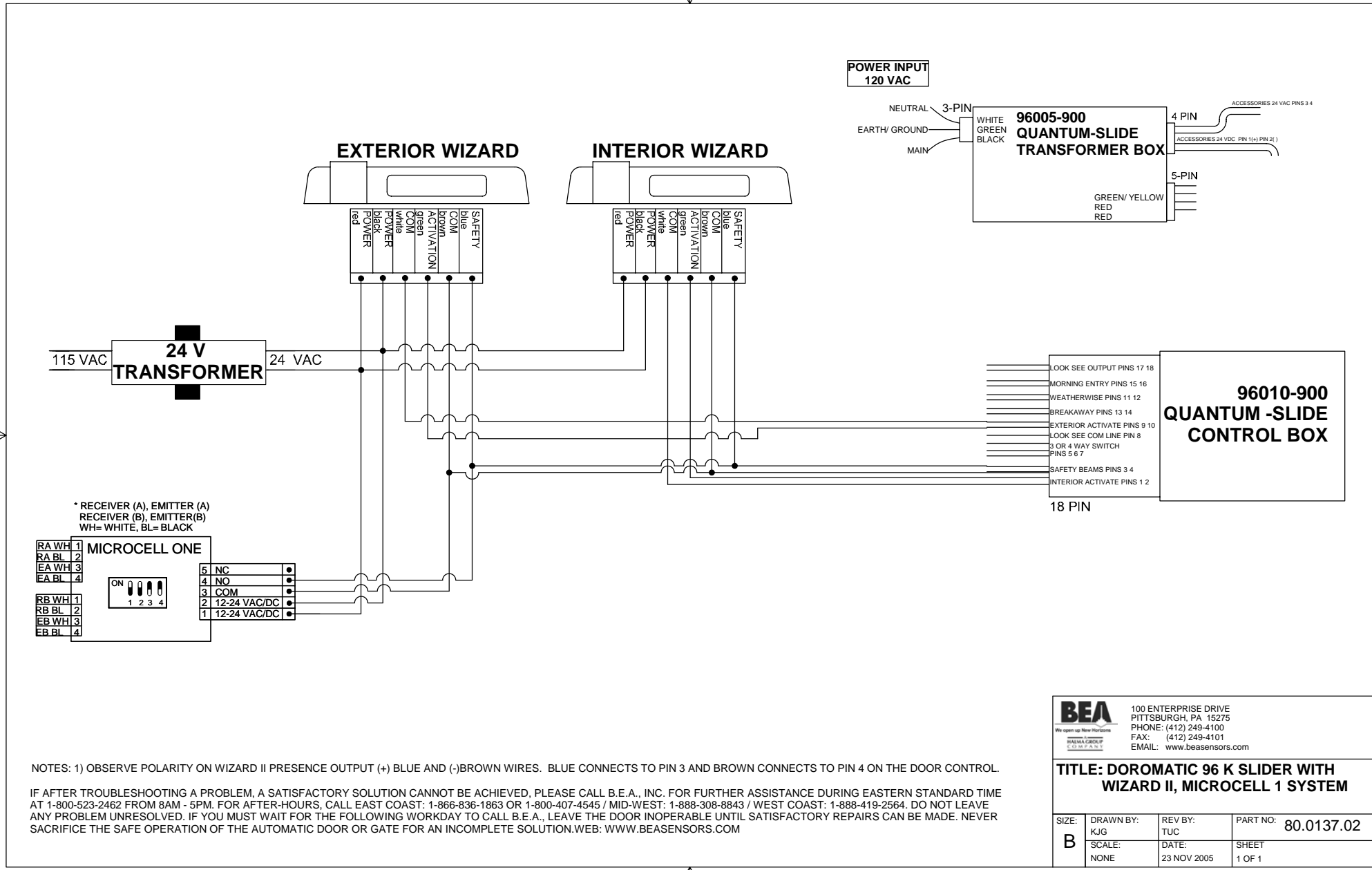

NOTES: 1) OBSERVE POLARITY ON WIZARD II PRESENCE OUTPUT (+) BLUE AND (-) BROWN WIRES. BLUE CONNECTS TO PIN 3 AND BROWN CONNECTS TO PIN 4 ON THE DOOR CONTROL.

IF AFTER TROUBLESHOOTING A PROBLEM, A SATISFACTORY SOLUTION CANNOT BE ACHIEVED, PLEASE CALL B.E.A., INC. FOR FURTHER ASSISTANCE DURING EASTERN STANDARD TIME AT 1-800-523-2462 FROM 8AM - 5PM. FOR AFTER-HOURS, CALL EAST COAST: 1-866-836-1863 OR 1-800-407-4545 / MID-WEST: 1-888-308-8843 / WEST COAST: 1-888-419-2564. DO NOT LEAVE ANY PROBLEM UNRESOLVED. IF YOU MUST WAIT FOR THE FOLLOWING WORKDAY TO CALL B.E.A., LEAVE THE DOOR INOPERABLE UNTIL SATISFACTORY REPAIRS CAN BE MADE. NEVER SACRIFICE THE SAFE OPERATION OF THE AUTOMATIC DOOR OR GATE FOR AN INCOMPLETE SOLUTION. WEB: WWW.BEASENSORS.COM

		100 ENTERPRISE DRIVE PITTSBURGH, PA 15275 PHONE: (412) 249-4100 FAX: (412) 249-4101 EMAIL: www.beasensors.com	
<b>TITLE: DOROMATIC 96 K SLIDER WITH WIZARD II, MICROCELL 1 SYSTEM</b>			
SIZE: B	DRAWN BY: KJG	REV BY: TUC	PART NO: 80.0137.02
SCALE: NONE	DATE: 23 NOV 2005	SHEET: 1 OF 1	

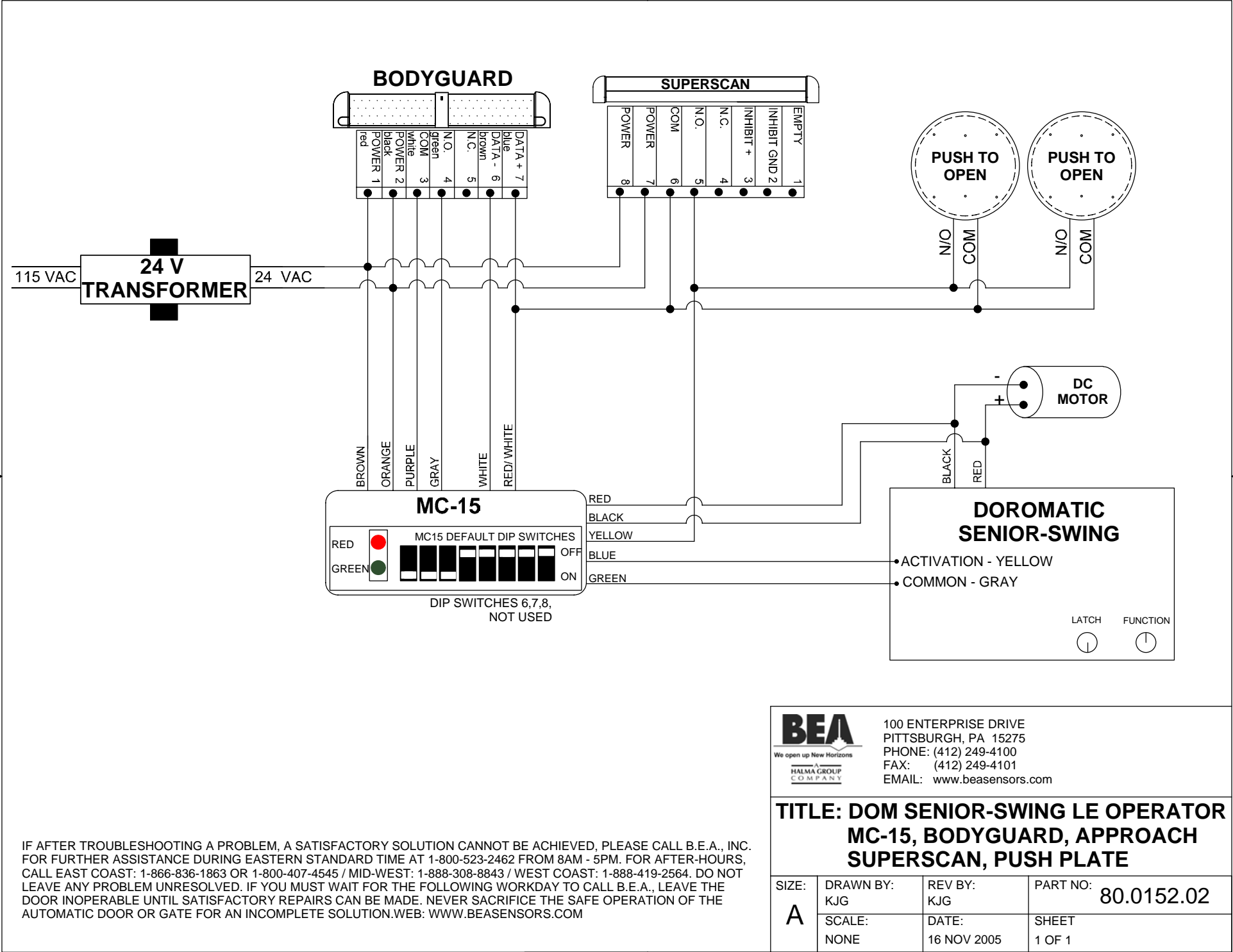

IF AFTER TROUBLESHOOTING A PROBLEM, A SATISFACTORY SOLUTION CANNOT BE ACHIEVED, PLEASE CALL B.E.A., INC. FOR FURTHER ASSISTANCE DURING EASTERN STANDARD TIME AT 1-800-523-2462 FROM 8AM - 5PM. FOR AFTER-HOURS, CALL EAST COAST: 1-866-836-1863 OR 1-800-407-4545 / MID-WEST: 1-888-308-8843 / WEST COAST: 1-888-419-2564. DO NOT LEAVE ANY PROBLEM UNRESOLVED. IF YOU MUST WAIT FOR THE FOLLOWING WORKDAY TO CALL B.E.A., LEAVE THE DOOR INOPERABLE UNTIL SATISFACTORY REPAIRS CAN BE MADE. NEVER SACRIFICE THE SAFE OPERATION OF THE AUTOMATIC DOOR OR GATE FOR AN INCOMPLETE SOLUTION.WEB: WWW.BEASENSORS.COM

**BEA**  
 We open up New Horizons  
 HALMA GROUP COMPANY  
 100 ENTERPRISE DRIVE  
 PITTSBURGH, PA 15275  
 PHONE: (412) 249-4100  
 FAX: (412) 249-4101  
 EMAIL: www.beasensors.com

**TITLE: DOM SENIOR-SWING LE OPERATOR  
 MC-15, BODYGUARD, APPROACH  
 SUPERSCAN, PUSH PLATE**

SIZE: <b>A</b>	DRAWN BY: KJG	REV BY: KJG	PART NO: <b>80.0152.02</b>
	SCALE: NONE	DATE: 16 NOV 2005	SHEET 1 OF 1

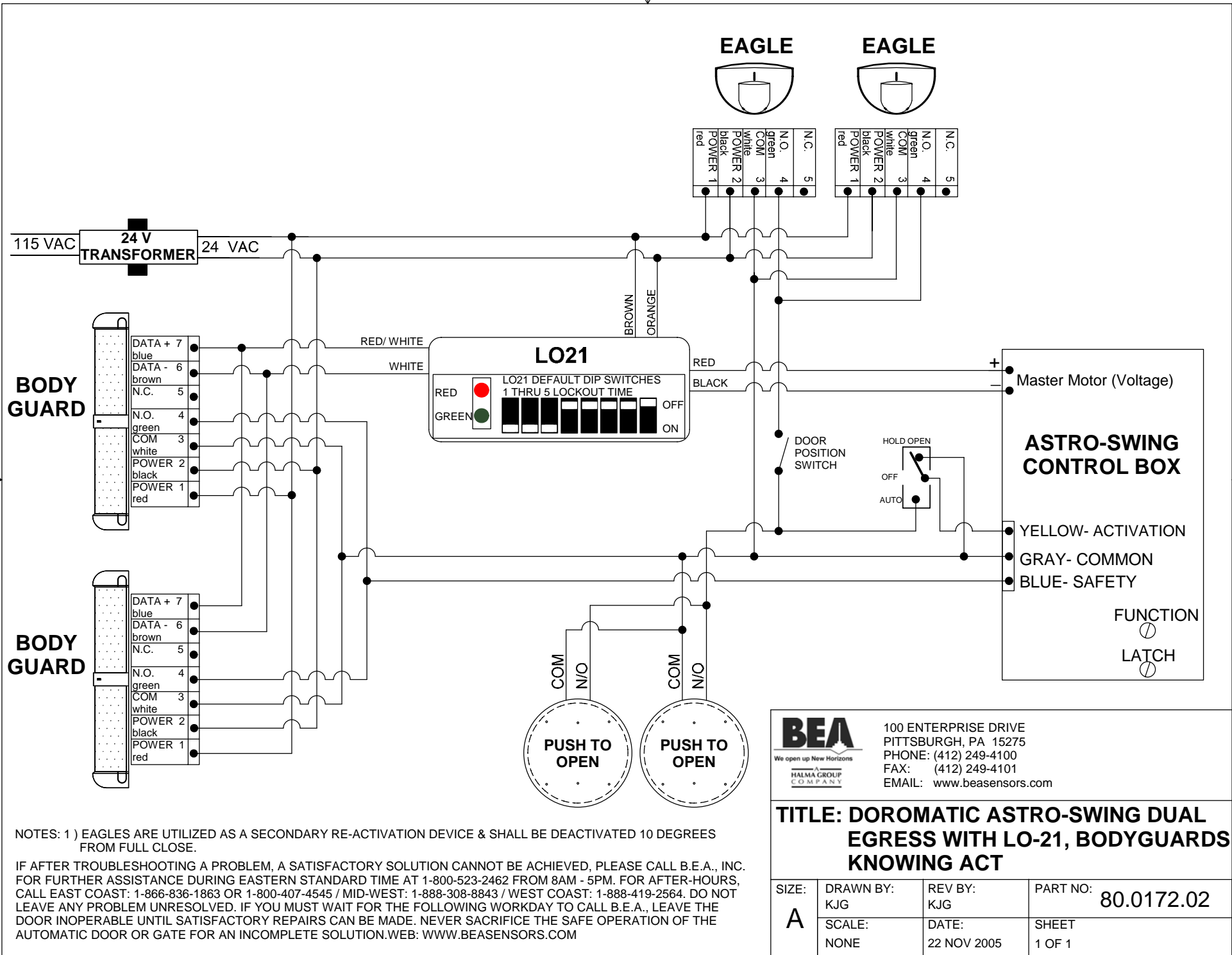

NOTES: 1 ) EAGLES ARE UTILIZED AS A SECONDARY RE-ACTIVATION DEVICE & SHALL BE DEACTIVATED 10 DEGREES FROM FULL CLOSE.

IF AFTER TROUBLESHOOTING A PROBLEM, A SATISFACTORY SOLUTION CANNOT BE ACHIEVED, PLEASE CALL B.E.A., INC. FOR FURTHER ASSISTANCE DURING EASTERN STANDARD TIME AT 1-800-523-2462 FROM 8AM - 5PM. FOR AFTER-HOURS, CALL EAST COAST: 1-866-836-1863 OR 1-800-407-4545 / MID-WEST: 1-888-308-8843 / WEST COAST: 1-888-419-2564. DO NOT LEAVE ANY PROBLEM UNRESOLVED. IF YOU MUST WAIT FOR THE FOLLOWING WORKDAY TO CALL B.E.A., LEAVE THE DOOR INOPERABLE UNTIL SATISFACTORY REPAIRS CAN BE MADE. NEVER SACRIFICE THE SAFE OPERATION OF THE AUTOMATIC DOOR OR GATE FOR AN INCOMPLETE SOLUTION.WEB: WWW.BEASENSORS.COM



100 ENTERPRISE DRIVE  
 PITTSBURGH, PA 15275  
 PHONE: (412) 249-4100  
 FAX: (412) 249-4101  
 EMAIL: www.beasensors.com

**TITLE: DOROMATIC ASTRO-SWING DUAL EGRESS WITH LO-21, BODYGUARDS KNOWING ACT**

SIZE: <b>A</b>	DRAWN BY: KJG	REV BY: KJG	PART NO: <b>80.0172.02</b>
	SCALE: NONE	DATE: 22 NOV 2005	SHEET 1 OF 1



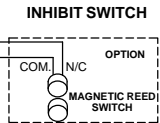
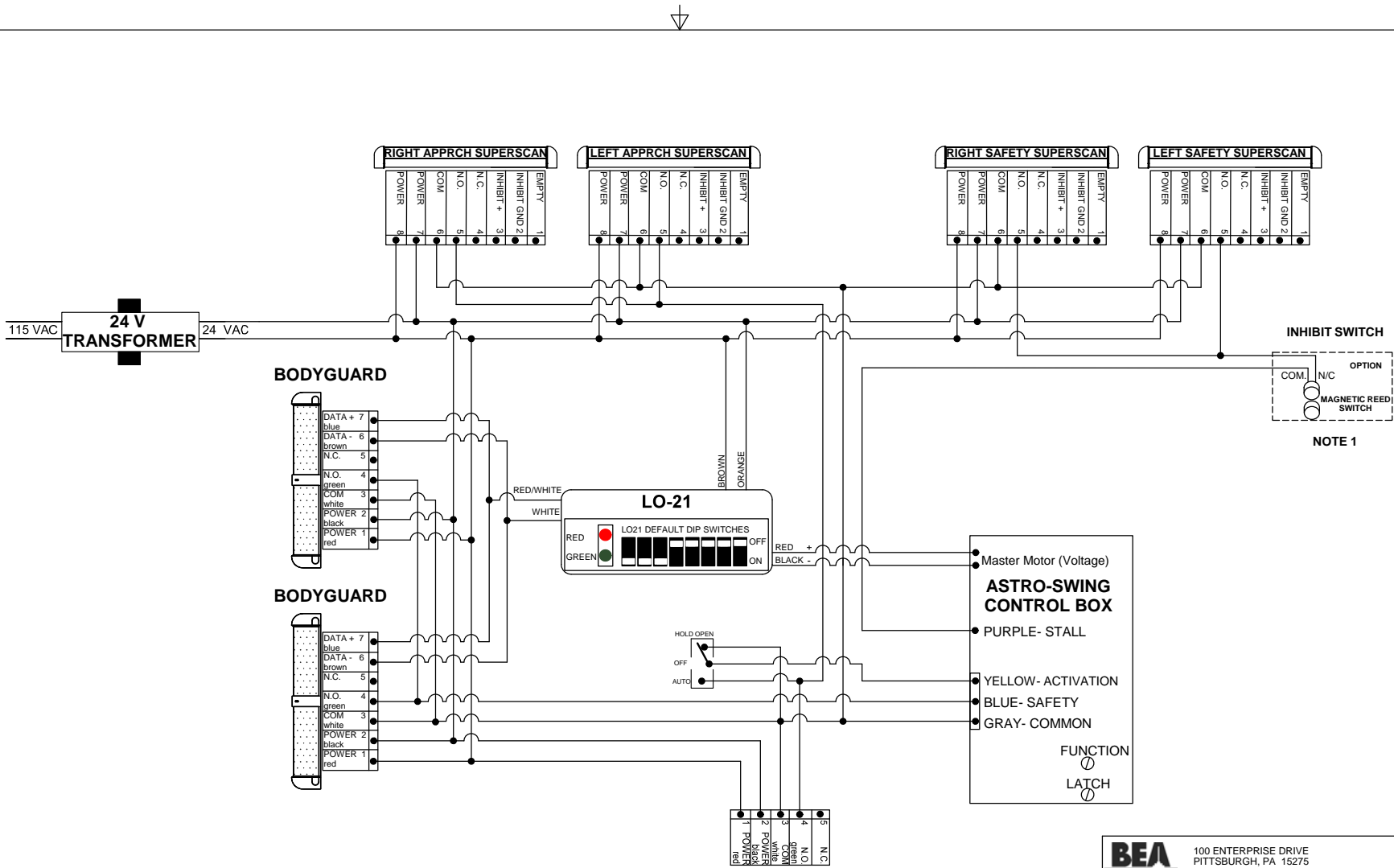

NOTE 1

- NOTES: 1) IF USING A MAGNETIC REED SWITCH TO INHIBIT, SET CONTROL FUNCTION DIAL TO 6. IF NOT USING INHIBIT SWITCH, SET CONTROL FUNCTION DIAL TO 5.  
 2) IF BODYGUARD HAS DOM INTERFACE CIRCUIT BOARD, IT MUST BE REMOVED  
 3) LO21 RED TO MOTOR "+" & LO21 BLACK TO MOTOR "-"  
 4) BODYGUARD SHALL BE 40" APART CENTER TO CENTER

IF AFTER TROUBLESHOOTING A PROBLEM, A SATISFACTORY SOLUTION CANNOT BE ACHIEVED, PLEASE CALL B.E.A., INC. FOR FURTHER ASSISTANCE DURING EASTERN STANDARD TIME AT 1-800-523-2462 FROM 8AM - 5PM. FOR AFTER-HOURS, CALL EAST COAST: 1-866-836-1863 OR 1-800-407-4545 / MID-WEST: 1-888-308-8843 / WEST COAST: 1-888-419-2564. DO NOT LEAVE ANY PROBLEM UNRESOLVED. IF YOU MUST WAIT FOR THE FOLLOWING WORKDAY TO CALL B.E.A., LEAVE THE DOOR INOPERABLE UNTIL SATISFACTORY REPAIRS CAN BE MADE. NEVER SACRIFICE THE SAFE OPERATION OF THE AUTOMATIC DOOR OR GATE FOR AN INCOMPLETE SOLUTION. WEB: WWW.BEASENSORS.COM

		100 ENTERPRISE DRIVE PITTSBURGH, PA 15275 PHONE: (412) 249-4100 FAX: (412) 249-4101 EMAIL: www.beasensors.com	
<b>TITLE: DOROMATIC ASTRO-SWING          DUAL EGRESS WITH PARALLAX 2          SYSTEM AND LO21</b>			
SIZE: <b>B</b>	DRAWN BY: KJG	REV BY: WJR	PART NO: <b>80.0173.03</b>
SCALE: NONE	DATE: 25 AUG 2008	SHEET 1 OF 1	

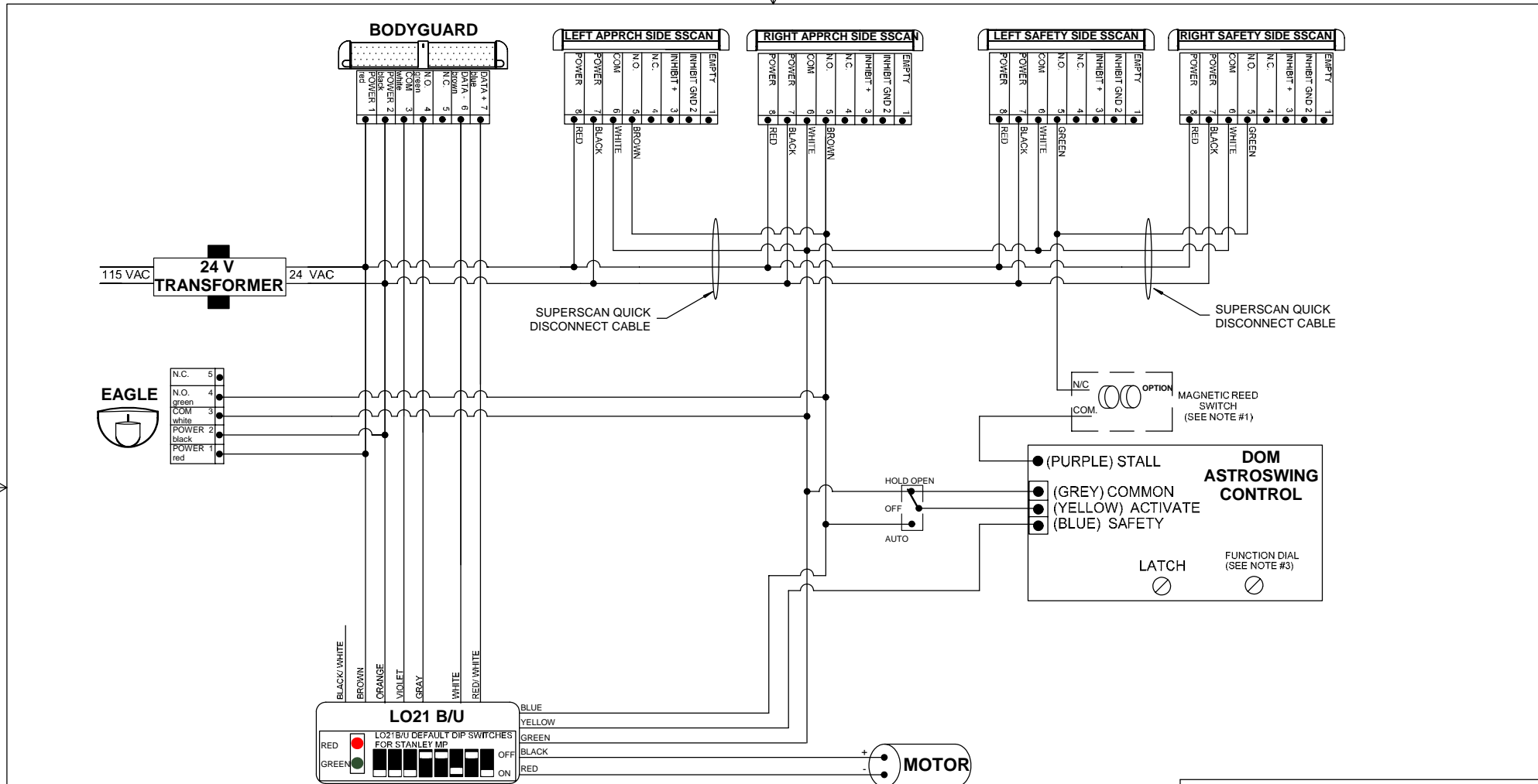

- NOTES: 1) THE MAGNETIC REED SWITCH SHALL OPEN AT APPROX. 65-70 DEGREES.  
 2) LO21B/U DIP SWITCHES: 1-5 (LOCKOUT TIME MAY VARY), #6 (DOWN/ON), #7 (UP/OFF), #8 (DOWN/ON)  
 3) IF USING A MAGNETIC REED SWITCH TO INHIBIT, SET CONTROL FUNCTION DIAL TO 6. IF NOT USING INHIBIT SWITCH, SET CONTROL FUNCTION DIAL TO 5.

IF AFTER TROUBLESHOOTING A PROBLEM, A SATISFACTORY SOLUTION CANNOT BE ACHIEVED, PLEASE CALL B.E.A., INC. FOR FURTHER ASSISTANCE DURING EASTERN STANDARD TIME AT 1-800-523-2462 FROM 8AM - 5PM. FOR AFTER-HOURS, CALL EAST COAST: 1-866-836-1863 OR 1-800-407-4545 / MID-WEST: 1-888-308-8843 / WEST COAST: 1-888-419-2564. DO NOT LEAVE ANY PROBLEM UNRESOLVED. IF YOU MUST WAIT FOR THE FOLLOWING WORKDAY TO CALL B.E.A., LEAVE THE DOOR INOPERABLE UNTIL SATISFACTORY REPAIRS CAN BE MADE. NEVER SACRIFICE THE SAFE OPERATION OF THE AUTOMATIC DOOR OR GATE FOR AN INCOMPLETE SOLUTION. WEB: WWW.BEASENSORS.COM

		100 ENTERPRISE DRIVE PITTSBURGH, PA 15275 PHONE: (412) 249-4100 FAX: (412) 249-4101 EMAIL: www.beasensors.com	
<b>TITLE: DOM ASTROSWING WITH PARALLAX 2 SYSTEM (LO21B/U) Q-DISCONNECT ON SAFETY SIDE</b>			
SIZE: <b>B</b>	DRAWN BY: KJG	REV BY: TUC	PART NO: <b>80.0179.02</b>
SCALE: NONE	DATE: 01 DEC 2005	SHEET: 1 OF 1	

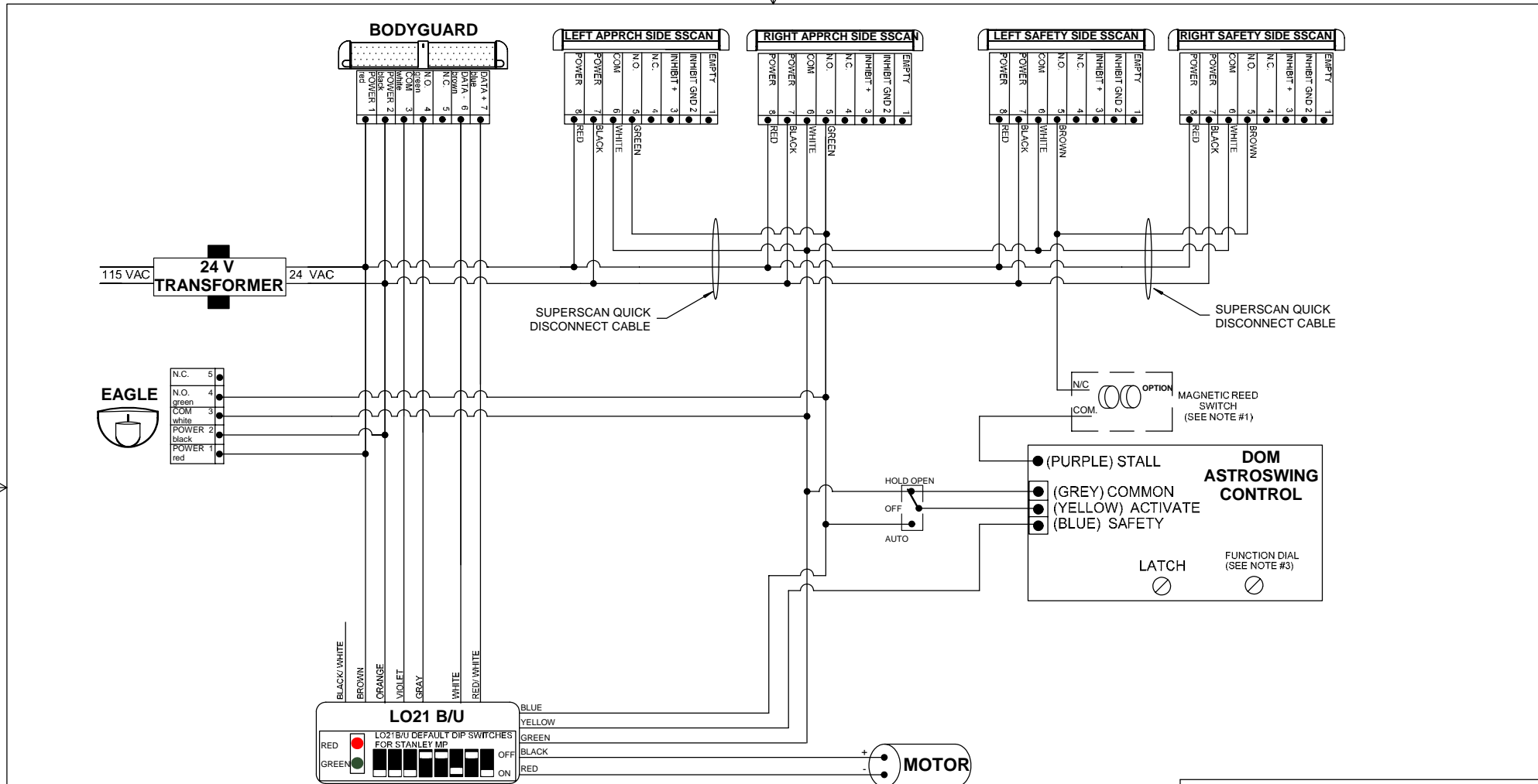

- NOTES: 1) THE MAGNETIC REED SWITCH SHALL OPEN AT APPROX. 65-70 DEGREES.  
 2) LO21B/U DIP SWITCHES: 1-5 (LOCKOUT TIME MAY VARY), #6 (DOWN/ON), #7 (UP/OFF), #8 (DOWN/ON)  
 3) IF USING A MAGNETIC REED SWITCH TO INHIBIT, SET CONTROL FUNCTION DIAL TO 6. IF NOT USING INHIBIT SWITCH, SET CONTROL FUNCTION DIAL TO 5.

IF AFTER TROUBLESHOOTING A PROBLEM, A SATISFACTORY SOLUTION CANNOT BE ACHIEVED, PLEASE CALL B.E.A., INC. FOR FURTHER ASSISTANCE DURING EASTERN STANDARD TIME AT 1-800-523-2462 FROM 8AM - 5PM. FOR AFTER-HOURS, CALL EAST COAST: 1-866-836-1863 OR 1-800-407-4545 / MID-WEST: 1-888-308-8843 / WEST COAST: 1-888-419-2564. DO NOT LEAVE ANY PROBLEM UNRESOLVED. IF YOU MUST WAIT FOR THE FOLLOWING WORKDAY TO CALL B.E.A., LEAVE THE DOOR INOPERABLE UNTIL SATISFACTORY REPAIRS CAN BE MADE. NEVER SACRIFICE THE SAFE OPERATION OF THE AUTOMATIC DOOR OR GATE FOR AN INCOMPLETE SOLUTION.WEB: WWW.BEASENSORS.COM

		100 ENTERPRISE DRIVE PITTSBURGH, PA 15275 PHONE: (412) 249-4100 FAX: (412) 249-4101 EMAIL: www.beasensors.com	
<b>TITLE: DOM ASTROSWING WITH PARALLAX 2 SYSTEM (LO21B/U) Q-DISCONNECT ON APPROCH SIDE</b>			
SIZE: <b>B</b>	DRAWN BY: KJG	REV BY: TUC	PART NO: 80.0180.02
SCALE: NONE	DATE: 01 DEC 2005	SHEET 1 OF 1	

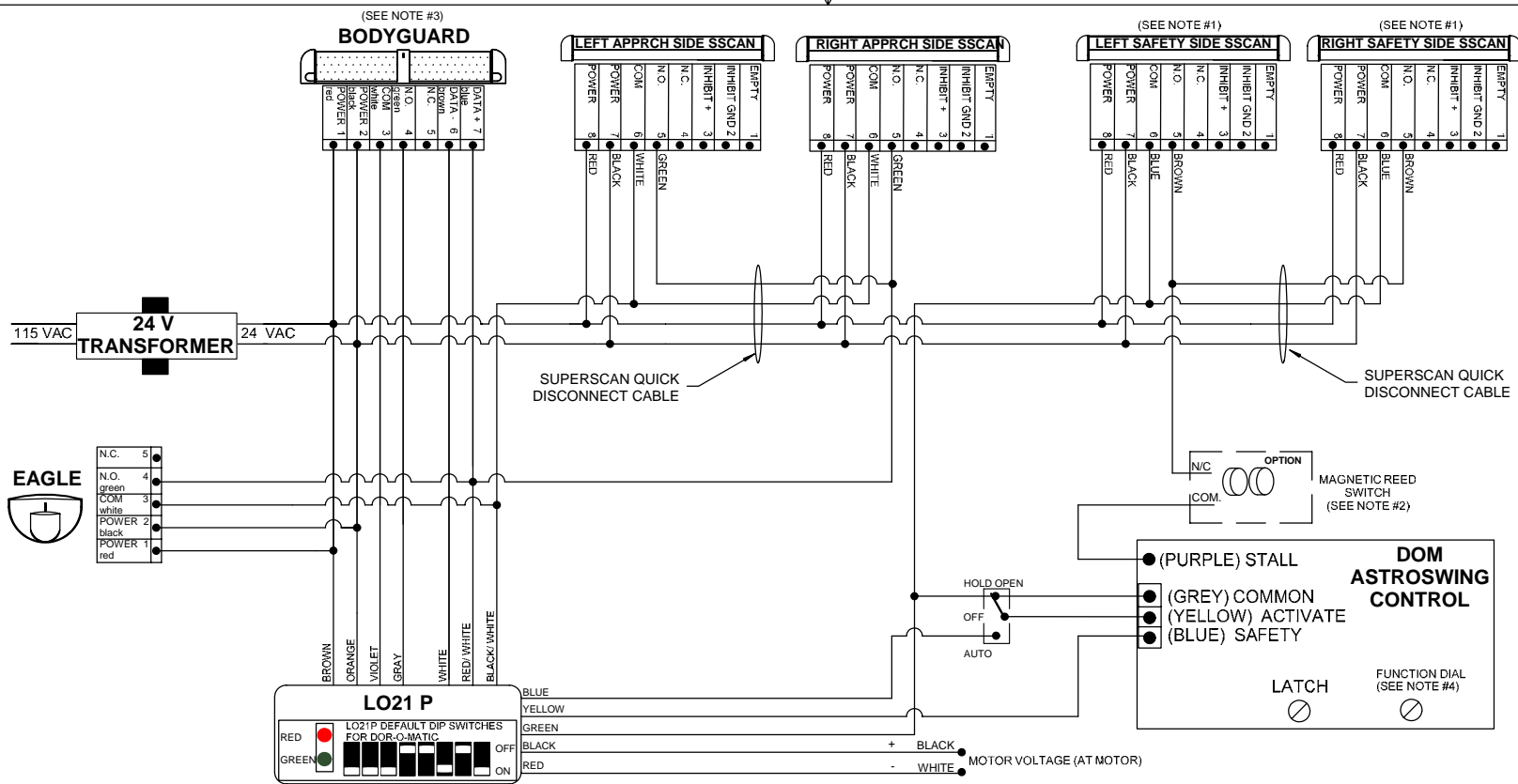

- NOTES: 1 ) INSERT SAFETY SIDE SUPERSCAN BLUE WIRE INTO PIN 6, BROWN WIRE INTO PIN 5, AND WHITE WIRE INTO PIN 1.  
 2 ) THE MAGNETIC REED SWITCH SHALL OPEN AT APPROX. 65-70 DEGREES.  
 3 ) THE BODYGUARD RELAY OUTPUT FUNCTION MUST BE CHANGED TO #2.  
 4 ) IF USING A MAGNETIC REED SWITCH TO INHIBIT, SET CONTROL FUNCTION DIAL TO 6. IF NOT USING INHIBIT SWITCH, SET CONTROL FUNCTION DIAL TO 5.

IF AFTER TROUBLESHOOTING A PROBLEM, A SATISFACTORY SOLUTION CANNOT BE ACHIEVED, PLEASE CALL B.E.A., INC. FOR FURTHER ASSISTANCE DURING EASTERN STANDARD TIME AT 1-800-523-2462 FROM 8AM - 5PM. FOR AFTER-HOURS, CALL EAST COAST: 1-866-836-1863 OR 1-800-407-4545 / MID-WEST: 1-888-308-8843 / WEST COAST: 1-888-419-2564. DO NOT LEAVE ANY PROBLEM UNRESOLVED. IF YOU MUST WAIT FOR THE FOLLOWING WORKDAY TO CALL B.E.A., LEAVE THE DOOR INOPERABLE UNTIL SATISFACTORY REPAIRS CAN BE MADE. NEVER SACRIFICE THE SAFE OPERATION OF THE AUTOMATIC DOOR OR GATE FOR AN INCOMPLETE SOLUTION.WEB: WWW.BEASENSORS.COM

		100 ENTERPRISE DRIVE PITTSBURGH, PA 15275 PHONE: (412) 249-4100 FAX: (412) 249-4101 EMAIL: www.beasensors.com	
<b>TITLE: DOROMATIC ASTROSOWING WITH LO-21P PARALLAX II SYSTEM Q-DISCONNECT ON APPROACH SIDE</b>			
SIZE:	DRAWN BY:	REV BY:	PART NO:
<b>B</b>	KJG	KJG	<b>80.0195.03</b>
SCALE:	DATE:	SHEET	
NONE	28 NOV 2005	1 OF 1	

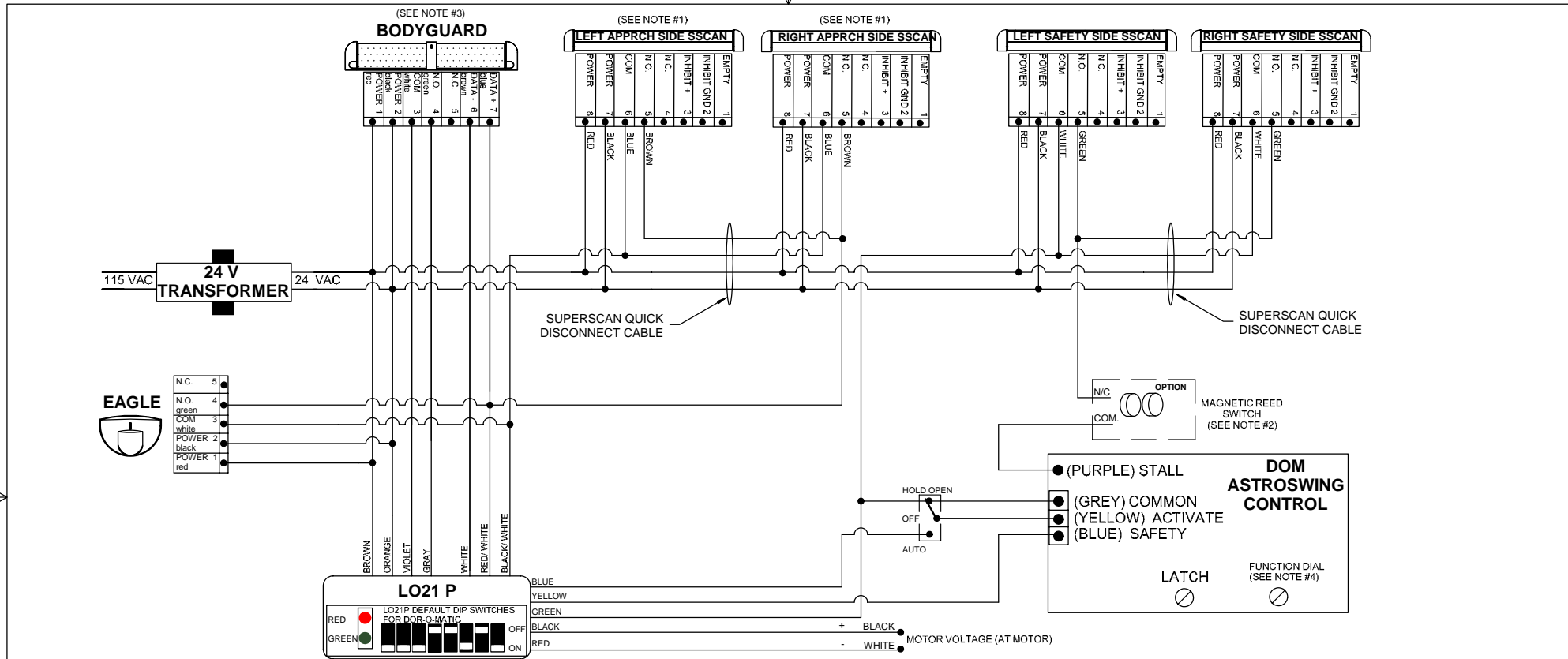

- NOTES: 1 ) INSERT SAFETY SIDE SUPERSCAN BLUE WIRE INTO PIN 6, BROWN WIRE INTO PIN 5, AND WHITE WIRE INTO PIN 1.  
 2 ) THE MAGNETIC REED SWITCH SHALL OPEN AT APPROX. 65-70 DEGREES.  
 3 ) THE BODYGUARD RELAY OUTPUT FUNCTION MUST BE CHANGED TO #2.  
 4 ) IF USING A MAGNETIC REED SWITCH TO INHIBIT, SET CONTROL FUNCTION DIAL TO 6. IF NOT USING INHIBIT SWITCH, SET CONTROL FUNCTION DIAL TO 5.

IF AFTER TROUBLESHOOTING A PROBLEM, A SATISFACTORY SOLUTION CANNOT BE ACHIEVED, PLEASE CALL B.E.A., INC. FOR FURTHER ASSISTANCE DURING EASTERN STANDARD TIME AT 1-800-523-2462 FROM 8AM - 5PM. FOR AFTER-HOURS, CALL EAST COAST: 1-866-836-1863 OR 1-800-407-4545 / MID-WEST: 1-888-308-8843 / WEST COAST: 1-888-419-2564. DO NOT LEAVE ANY PROBLEM UNRESOLVED. IF YOU MUST WAIT FOR THE FOLLOWING WORKDAY TO CALL B.E.A., LEAVE THE DOOR INOPERABLE UNTIL SATISFACTORY REPAIRS CAN BE MADE. NEVER SACRIFICE THE SAFE OPERATION OF THE AUTOMATIC DOOR OR GATE FOR AN INCOMPLETE SOLUTION. WEB: WWW.BEASENSORS.COM

		100 ENTERPRISE DRIVE PITTSBURGH, PA 15275 PHONE: (412) 249-4100 FAX: (412) 249-4101 EMAIL: www.beasensors.com	
<b>TITLE: DOROMATIC ASTROSOWING WITH LO-21P PARALLAX II SYSTEM Q-DISCONNECT ON SAFTY SIDE</b>			
SIZE:	DRAWN BY:	REV BY:	PART NO:
B	KJG	KJG	80.0197.03
SCALE:	NONE	DATE:	SHEET
		28 NOV 2005	1 OF 1

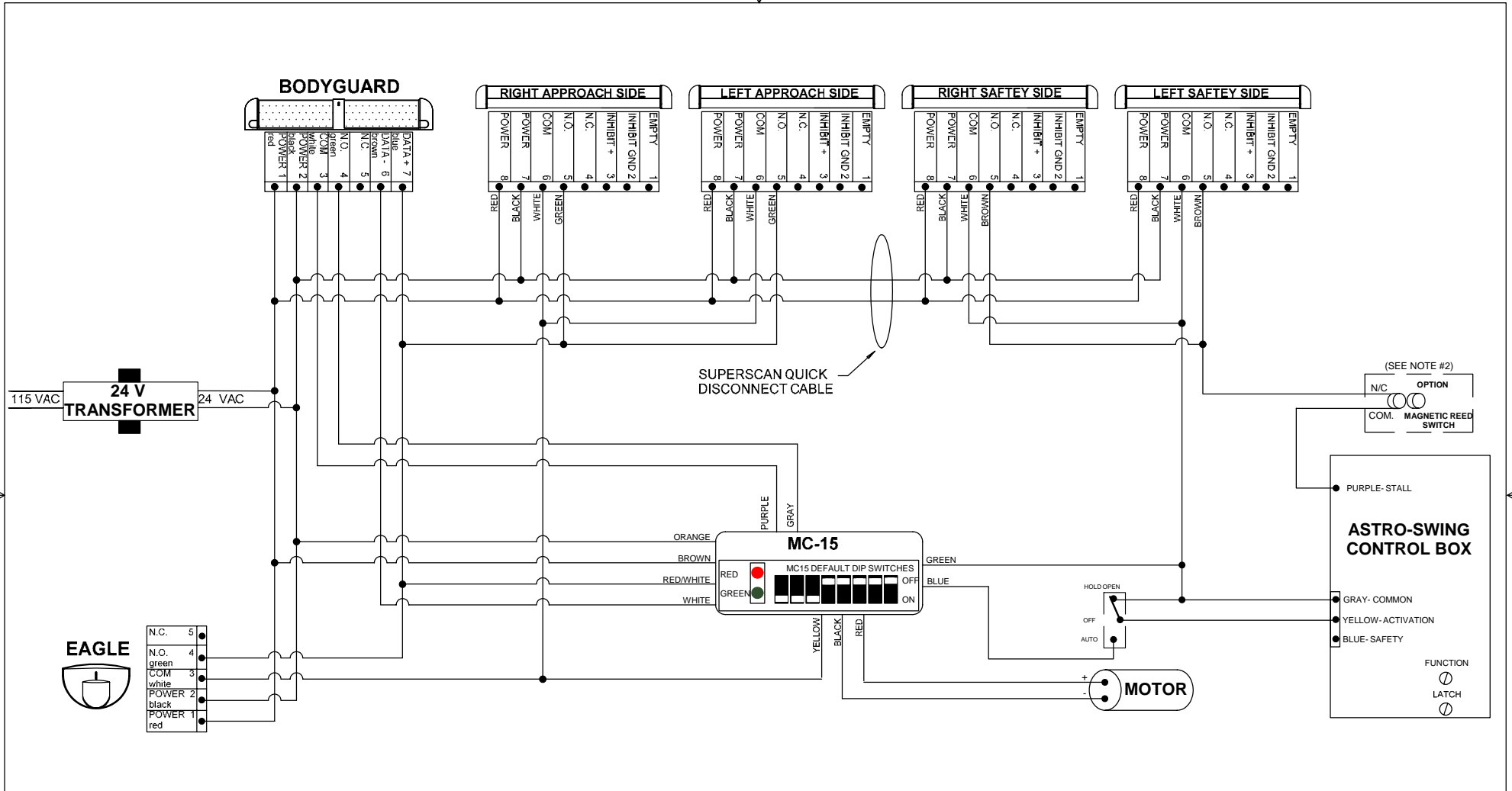

- NOTES: 1) THE MAGNETIC REED SWITCH SHALL OPEN AT APPROX. 65-70 DEGREES.  
 2) MC15 DIP SWITCHES: 1-5 LOCKOUT TIME WILL VARY, #6-8, (NOT USED).  
 3) IF USING A MAGNETIC REED SWITCH TO INHIBIT, SET CONTROL FUNCTION DIAL TO 6. IF NOT USING INHIBIT SWITCH, SET CONTROL FUNCTION DIAL TO 5.  
 4) IF BODYGUARD HAS DOM INTERFACE CIRCUIT BOARD, IT MUST BE REMOVED.

IF AFTER TROUBLESHOOTING A PROBLEM, A SATISFACTORY SOLUTION CANNOT BE ACHIEVED, PLEASE CALL B.E.A., INC. FOR FURTHER ASSISTANCE DURING EASTERN STANDARD TIME AT 1-800-523-2462 FROM 8AM - 5PM. FOR AFTER-HOURS, CALL EAST COAST: 1-866-836-1863 OR 1-800-407-4545 / MID-WEST: 1-888-308-8843 / WEST COAST: 1-888-419-2564. DO NOT LEAVE ANY PROBLEM UNRESOLVED. IF YOU MUST WAIT FOR THE FOLLOWING WORKDAY TO CALL B.E.A., LEAVE THE DOOR INOPERABLE UNTIL SATISFACTORY REPAIRS CAN BE MADE. NEVER SACRIFICE THE SAFE OPERATION OF THE AUTOMATIC DOOR OR GATE FOR AN INCOMPLETE SOLUTION. WEB: WWW.BEASENSORS.COM

		100 ENTERPRISE DRIVE PITTSBURGH, PA 15275 PHONE: (412) 249-4100 FAX: (412) 249-4101 EMAIL: www.beasensors.com	
<b>TITLE: DOROMATIC ASTRO-SWING WITH PARALLAX 2 SYSTEM (MC15) Q-DISCONNECT ON APPROACH SIDE</b>			
SIZE: B	DRAWN BY: TUC	REV BY: TUC	PART NO: 80.0206.01
SCALE: NONE	DATE: 09 NOV 2005	SHEET: 1 OF 1	

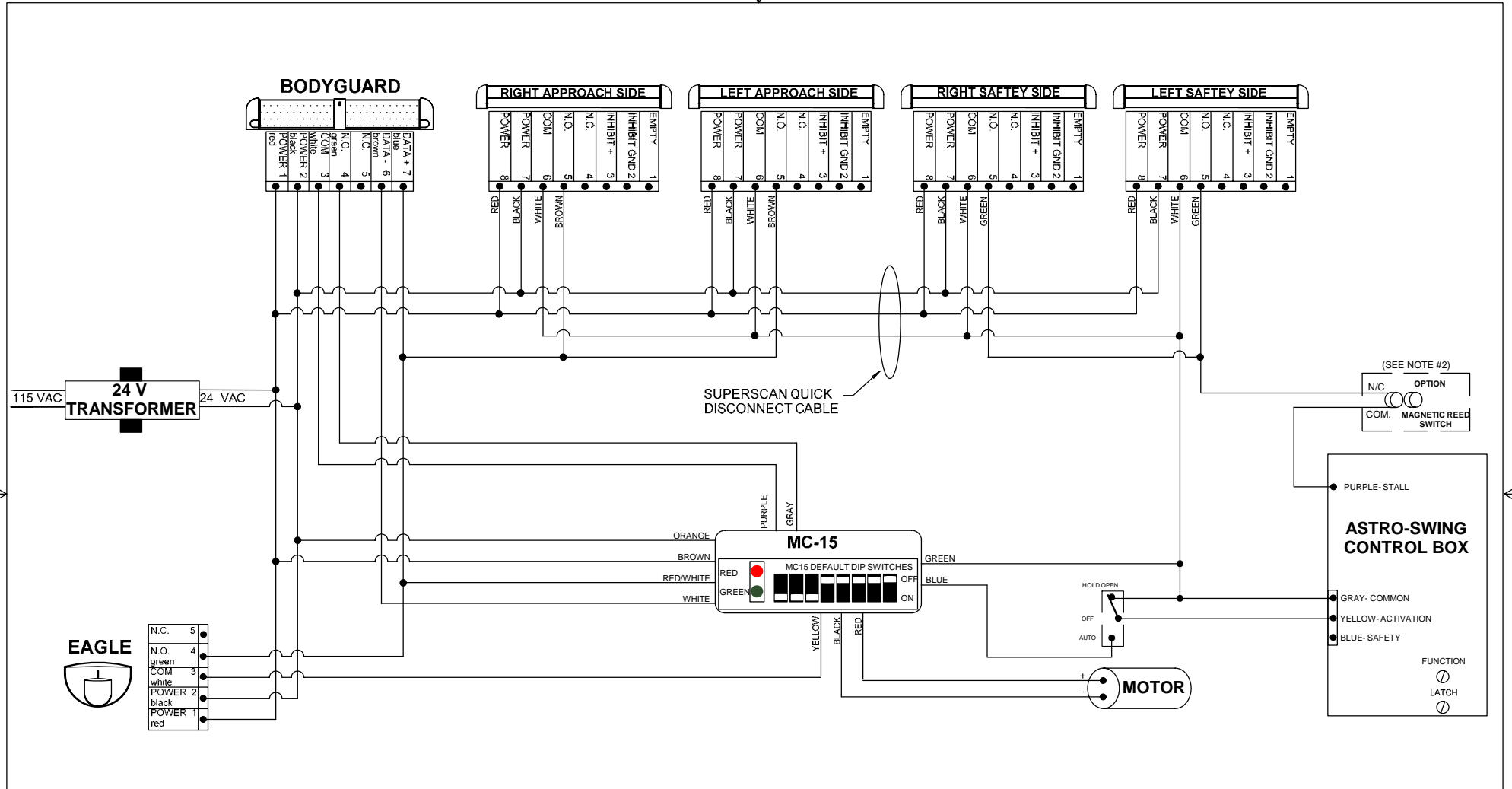

- NOTES: 1) THE MAGNETIC REED SWITCH SHALL OPEN AT APPROX. 65-70 DEGREES.  
 2) MC15 DIP SWITCHES: 1-5 LOCKOUT TIME WILL VARY, #6-8, (NOT USED).  
 3) IF USING A MAGNETIC REED SWITCH TO INHIBIT, SET CONTROL FUNCTION DIAL TO 6. IF NOT USING INHIBIT SWITCH, SET CONTROL FUNCTION DIAL TO 5.  
 4) IF BODYGUARD HAS DOM INTERFACE CIRCUIT BOARD, IT MUST BE REMOVED.

IF AFTER TROUBLESHOOTING A PROBLEM, A SATISFACTORY SOLUTION CANNOT BE ACHIEVED, PLEASE CALL B.E.A., INC. FOR FURTHER ASSISTANCE DURING EASTERN STANDARD TIME AT 1-800-523-2462 FROM 8AM - 5PM. FOR AFTER-HOURS, CALL EAST COAST: 1-866-836-1863 OR 1-800-407-4545 / MID-WEST: 1-888-308-8843 / WEST COAST: 1-888-419-2564. DO NOT LEAVE ANY PROBLEM UNRESOLVED. IF YOU MUST WAIT FOR THE FOLLOWING WORKDAY TO CALL B.E.A., LEAVE THE DOOR INOPERABLE UNTIL SATISFACTORY REPAIRS CAN BE MADE. NEVER SACRIFICE THE SAFE OPERATION OF THE AUTOMATIC DOOR OR GATE FOR AN INCOMPLETE SOLUTION.WEB: WWW.BEASENSORS.COM

		100 ENTERPRISE DRIVE PITTSBURGH, PA 15275 PHONE: (412) 249-4100 FAX: (412) 249-4101 EMAIL: www.beasensors.com	
<b>TITLE: POROMATIC ASTRO-SWING WITH PARALLAX 2 SYSTEM (MC15) Q-DISCONNECT ON SAFETY SIDE</b>			
SIZE: B	DRAWN BY: TUC SCALE: NONE	REV BY: TUC DATE: 09 NOV 2005	PART NO: 80.0207.01 SHEET: 1 OF 1

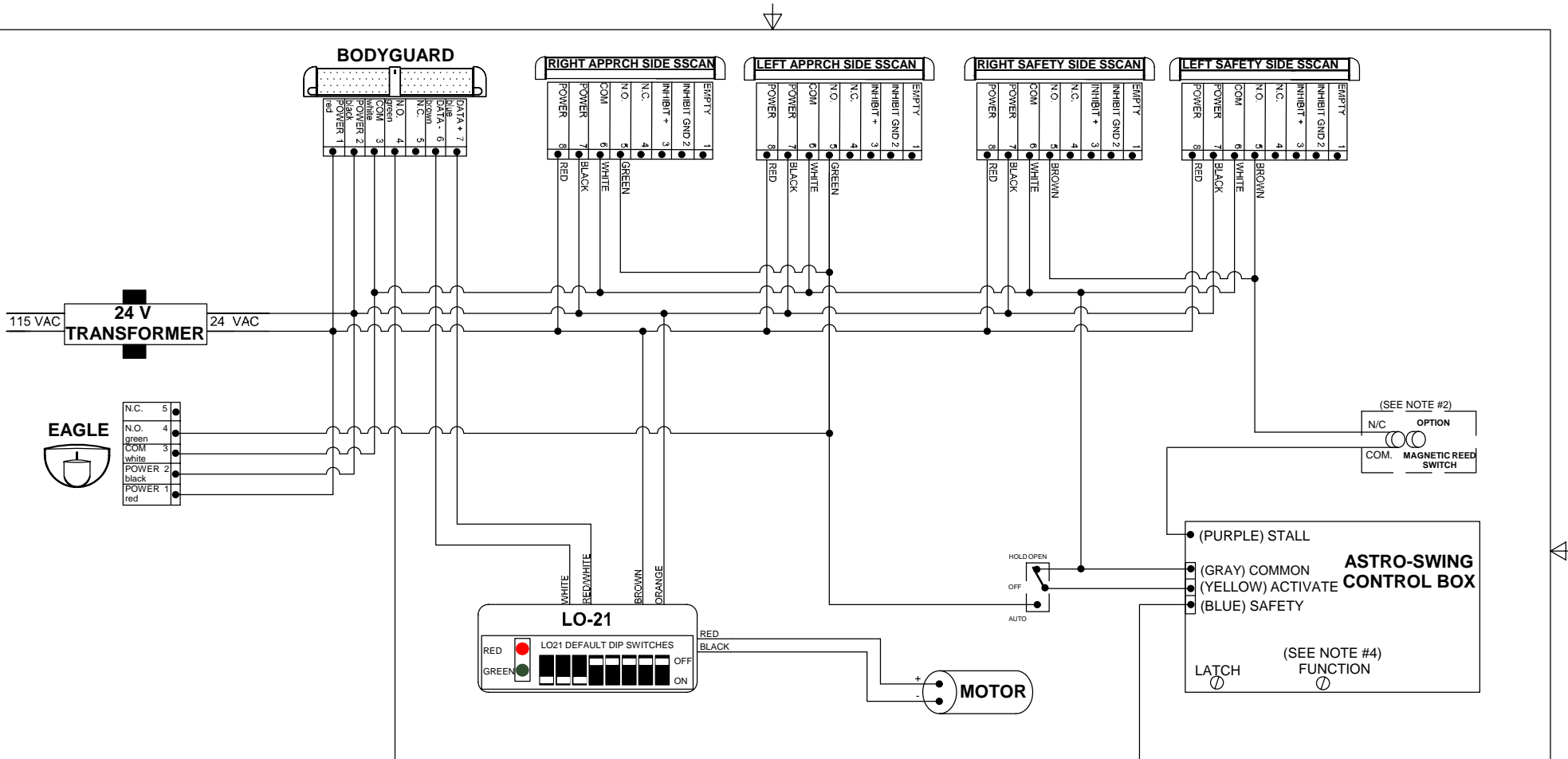

NOTES: 1) IF BODYGUARD HAS DOM INTERFACE CIRCUIT BOARD, IT MUST BE REMOVED.

2) THE MAGNETIC REED SWITCH SHALL OPEN AT APPROX. 65-70 DEGREES.

3) LO21 DIP SWITCHES: 1-5 LOCKOUT TIME WILL VARY, #6-8, (NOT USED).

4) IF USING A MAGNETIC REED SWITCH TO INHIBIT, SET CONTROL FUNCTION DIAL TO 6. IF NOT USING INHIBIT SWITCH, SET CONTROL FUNCTION DIAL TO 5.

IF AFTER TROUBLESHOOTING A PROBLEM, A SATISFACTORY SOLUTION CANNOT BE ACHIEVED, PLEASE CALL B.E.A., INC. FOR FURTHER ASSISTANCE DURING EASTERN STANDARD TIME AT 1-800-523-2462 FROM 8AM - 5PM. FOR AFTER-HOURS, CALL EAST COAST: 1-866-836-1863 OR 1-800-407-4545 / MID-WEST: 1-888-308-8843 / WEST COAST: 1-888-419-2564. DO NOT LEAVE ANY PROBLEM UNRESOLVED. IF YOU MUST WAIT FOR THE FOLLOWING WORKDAY TO CALL B.E.A., LEAVE THE DOOR INOPERABLE UNTIL SATISFACTORY REPAIRS CAN BE MADE. NEVER SACRIFICE THE SAFE OPERATION OF THE AUTOMATIC DOOR OR GATE FOR AN INCOMPLETE SOLUTION. WEB: WWW.BEASENSORS.COM

		100 ENTERPRISE DRIVE PITTSBURGH, PA 15275 PHONE: (412) 249-4100 FAX: (412) 249-4101 EMAIL: www.beasensors.com	
<b>TITLE: DOROMATIC ASTRO-SWING WITH PARALLAX 2 SYSTEM (LO21) Q-DISC. ON APPROACH SIDE</b>			
SIZE: <b>B</b>	DRAWN BY: KJG	REV BY: TUC	PART NO: <b>80.0215.01</b>
SCALE: NONE	DATE: 13 OCT 2005	SHEET: 1 OF 1	



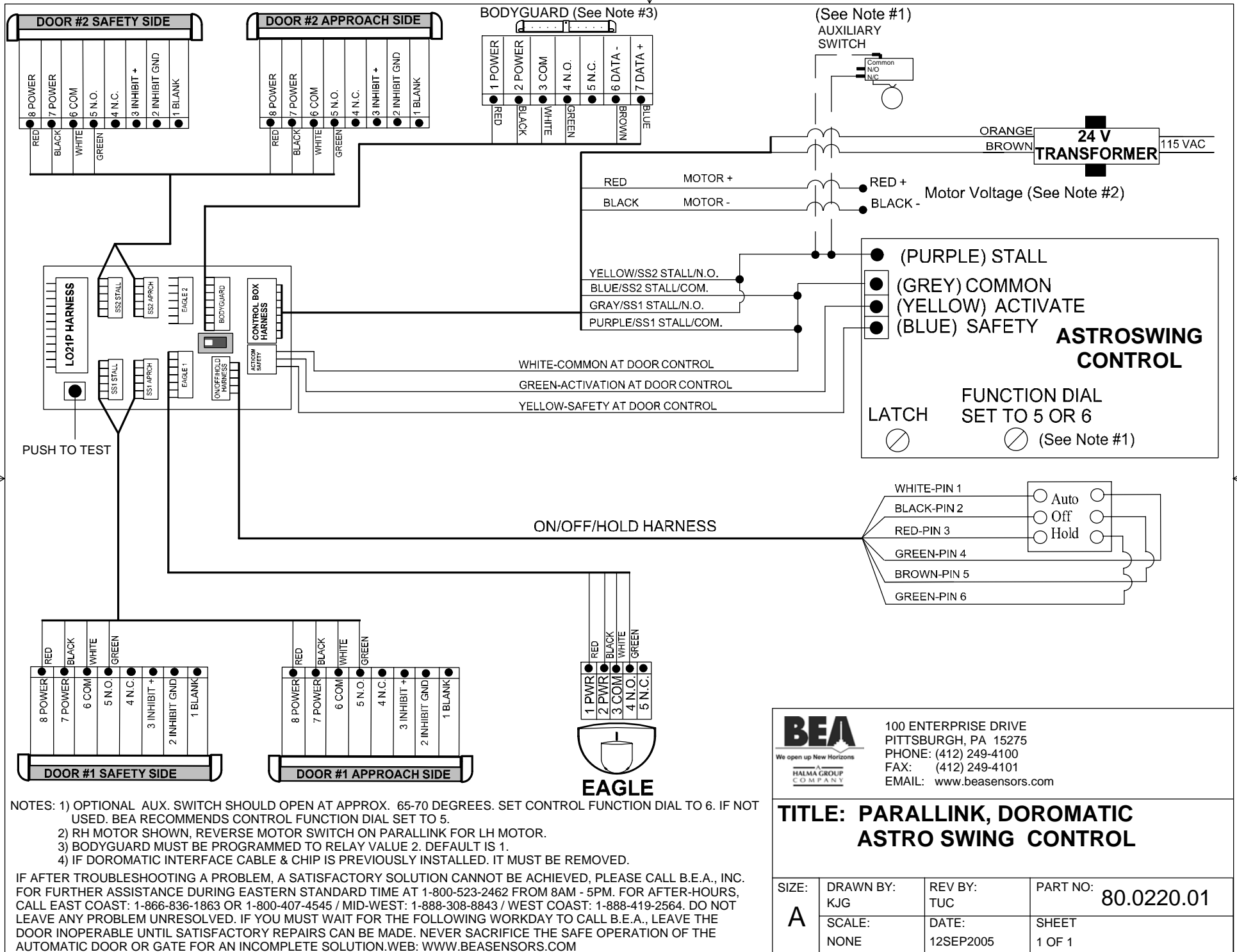

- NOTES: 1) OPTIONAL AUX. SWITCH SHOULD OPEN AT APPROX. 65-70 DEGREES. SET CONTROL FUNCTION DIAL TO 6. IF NOT USED, BEA RECOMMENDS CONTROL FUNCTION DIAL SET TO 5.  
 2) RH MOTOR SHOWN, REVERSE MOTOR SWITCH ON PARALLINK FOR LH MOTOR.  
 3) BODYGUARD MUST BE PROGRAMMED TO RELAY VALUE 2. DEFAULT IS 1.  
 4) IF DOROMATIC INTERFACE CABLE & CHIP IS PREVIOUSLY INSTALLED. IT MUST BE REMOVED.

IF AFTER TROUBLESHOOTING A PROBLEM, A SATISFACTORY SOLUTION CANNOT BE ACHIEVED, PLEASE CALL B.E.A., INC. FOR FURTHER ASSISTANCE DURING EASTERN STANDARD TIME AT 1-800-523-2462 FROM 8AM - 5PM. FOR AFTER-HOURS, CALL EAST COAST: 1-866-836-1863 OR 1-800-407-4545 / MID-WEST: 1-888-308-8843 / WEST COAST: 1-888-419-2564. DO NOT LEAVE ANY PROBLEM UNRESOLVED. IF YOU MUST WAIT FOR THE FOLLOWING WORKDAY TO CALL B.E.A., LEAVE THE DOOR INOPERABLE UNTIL SATISFACTORY REPAIRS CAN BE MADE. NEVER SACRIFICE THE SAFE OPERATION OF THE AUTOMATIC DOOR OR GATE FOR AN INCOMPLETE SOLUTION. WEB: WWW.BEASENSORS.COM



100 ENTERPRISE DRIVE  
 PITTSBURGH, PA 15275  
 PHONE: (412) 249-4100  
 FAX: (412) 249-4101  
 EMAIL: www.beasensors.com

**TITLE: PARALLINK, DOROMATIC  
 ASTRO SWING CONTROL**

SIZE: <b>A</b>	DRAWN BY: KJG	REV BY: TUC	PART NO: <b>80.0220.01</b>
	SCALE: NONE	DATE: 12SEP2005	SHEET 1 OF 1

LO-LINX SWING	GREEN ACT.	WHITE COM.	YELLOW SAF.	BLUE STALL	BROWN STAL COM.
BESAM 300	13	12	11	15, 17	16, 18
BESAM M/P	3	4	9	5	13
DOM	YELLOW	GREY	BLUE	PURPLE	GREY
GT 300/400	BLACK	RED	WHITE	WHITE	RED
GT MAG	6 BLACK	5 RED	4 WHITE	3 VIOLET	5 RED
HORTON 4180	2	3, 6, 8	4	10	3, 6, 8
HUNTER	ACT.	RTN	SAF. 1	SAF. 2	RTN
KM K	GREEN	WHITE	RED	YELLOW	WHITE
STANLEY "L"	ORANGE	YELLOW	RED	BLUE	YELLOW
STANLEY M/P	2	18	7	7	18
STANLEY 521	TB4-4	TB4-3	TB3-8	TB3-4	TB3-3
TORMAX TTXII	5	4	13	14	15

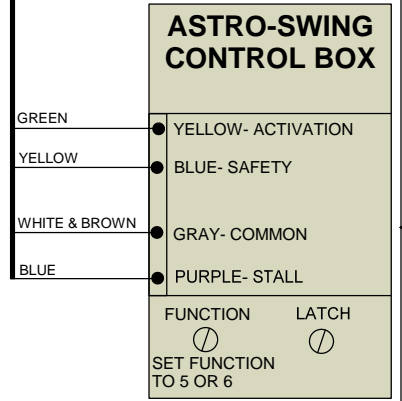
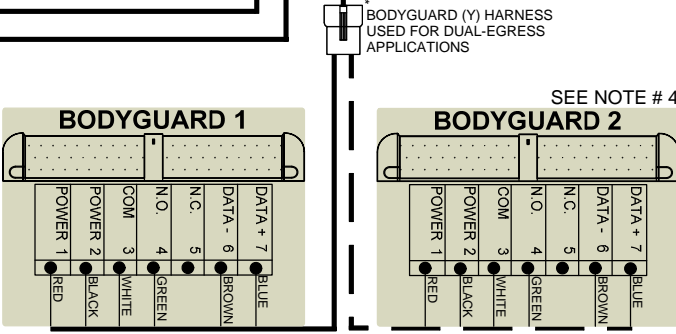
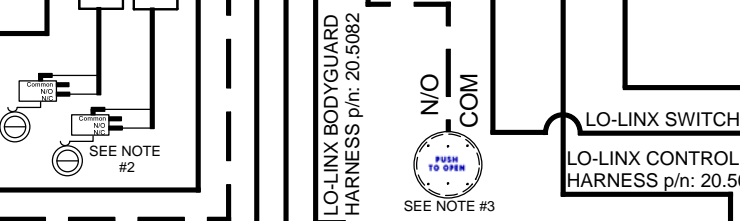
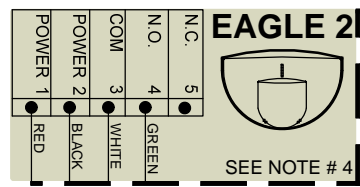
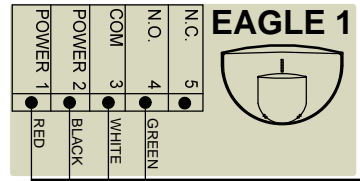
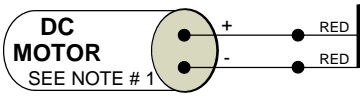
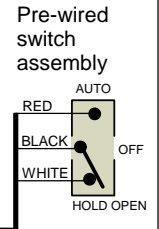
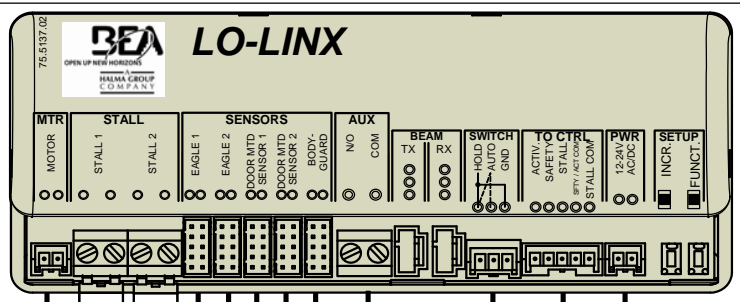

LO-LINX SUPERSCAN HARNESS p/n: 70.5071

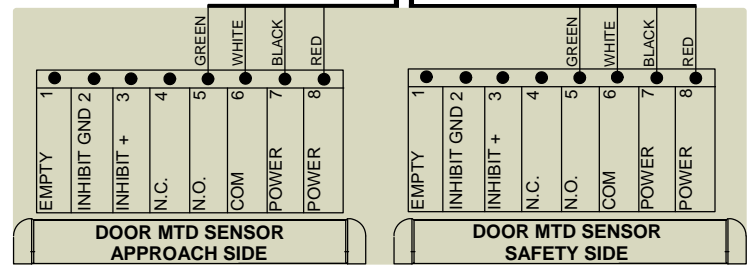
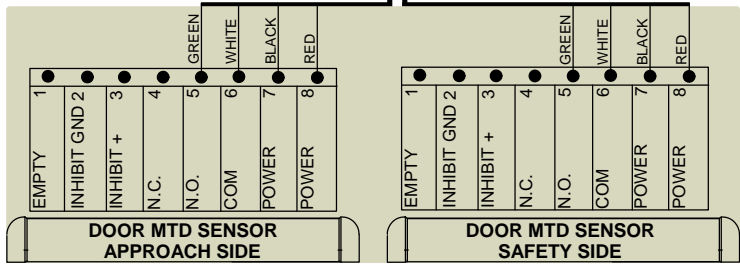

**NOTES:**

1. MOTOR CONNECTION IS TIED IN PARALLEL TO EXISTING MOTOR LEADS. NO RESPECT TO PALARITY IS REQUIRED.
2. EXTERNAL SWITCHES ARE REQUIRED IF INHIBIT DESIRED AT SWING SIDE SUPERSCANS, SWITCH OPENS UPON INHIBIT POINT.
3. THE KNOWING ACT SWITCH IS CONNECTED AT THE AUX INPUT AND CAN BE ANY DRY CONTACT DEVICE SUCH AS A PUSHPLATE, CARD READER, ETC. THE AUX INPUT IS REQUIRED FOR ALL INITIAL ACTIVATION WHEN FUNCTION 'FA' ON THE LO-LINX IS SET TO '01'.
4. THE SECOND BODYGUARD AND EAGLE ARE PRIMARILY USED IN DUAL-EGRESS APPLICATIONS. ENSURE BODYGUARD RELAY VALUE IS SET TO 2.

IF AFTER TROUBLESHOOTING A PROBLEM, A SATISFACTORY SOLUTION CANNOT BE ACHIEVED, PLEASE CALL B.E.A., INC. FOR FURTHER ASSISTANCE DURING EASTERN STANDARD TIME AT 1-800-523-2462 FROM 8AM - 5PM. FOR AFTER-HOURS, CALL EAST COAST: 1-866-836-1863 OR 1-800-407-4545 / MID-WEST: 1-888-308-8843 / WEST COAST: 1-888-419-2564. DO NOT LEAVE ANY PROBLEM UNRESOLVED. IF YOU MUST WAIT FOR THE FOLLOWING WORKDAY TO CALL B.E.A., LEAVE THE DOOR INOPERABLE UNTIL SATISFACTORY REPAIRS CAN BE MADE. NEVER SACRIFICE THE SAFE OPERATION OF THE AUTOMATIC DOOR OR GATE FOR AN INCOMPLETE SOLUTION. WEB: WWW.BEASENSORS.COM

OPEN UP NEW HORIZONS  
A HALMA GROUP COMPANY

100 ENTERPRISE DRIVE  
PITTSBURGH, PA 15275  
PHONE: (412) 249-4100  
FAX: (412) 249-4101  
EMAIL: www.beasensors.com

**TITLE: DOROMATIC LO-LINX SYSTEM**

SIZE: A	DRAWN BY: JED	REV BY: TUC	PART NO: 80.0242.05
SCALE: NONE	DATE: 10/15/2007	SHEET 1 OF 1	