

LO-LINX SWING	GREEN ACT.	WHITE COM.	YELLOW SAF.	BLUE STALL	BROWN STAL COM.
BESAM 300	3	12	11	5, 17	16, 18
BESAM M/P	3	4	9	5	13
DOM	YELLOW	GREY	BLUE	PURPLE	GREY
GT 300/400	BLACK	RED	WHITE	WHITE	RED
GT MAG	6 BLACK	5 RED	4 WHITE	3 VIOLET	5 RED
HORTON 480	2	3, 6, 8	4	10	3, 6, 8
HUNTER	ACT.	RTN	SAF. 1	SAF. 2	RTN
KM K	GREEN	WHITE	RED	YELLOW	WHITE
STANLEY "L"	ORANGE	YELLOW	RED	BLUE	YELLOW
STANLEY M/P	2	1, 8	7	7	1, 8
STANLEY 521	TB4-4	TB4-3	TB3-8	TB3-4	TB3-3
TORMAX TTXII	5	4	18	14	15

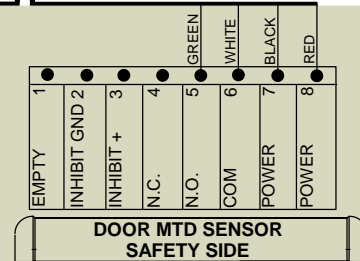
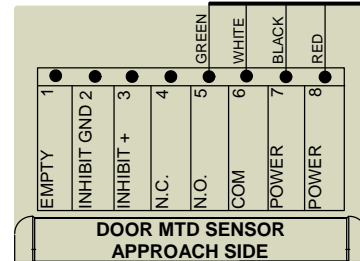
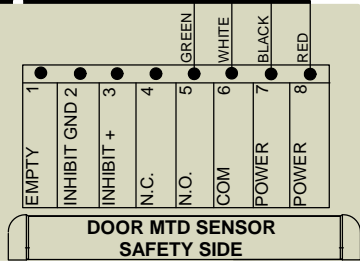
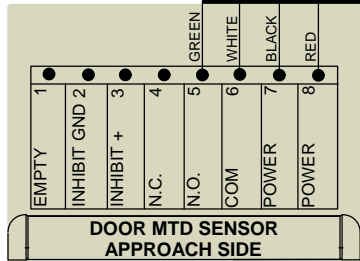
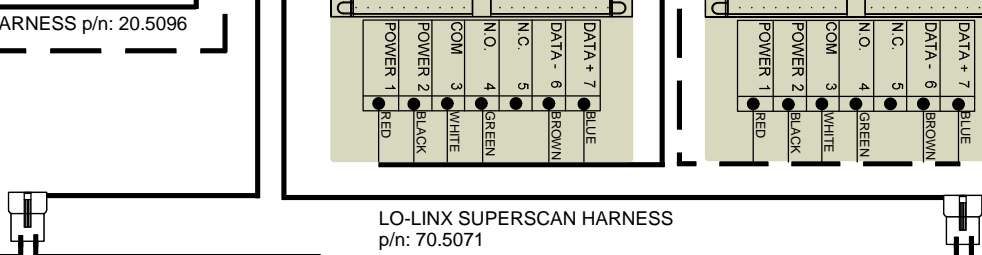
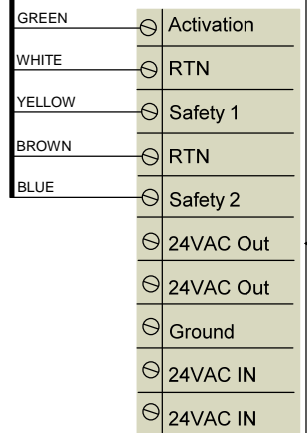
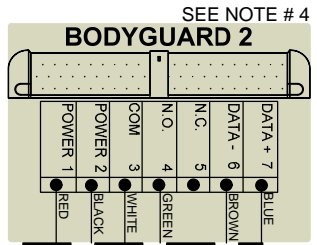
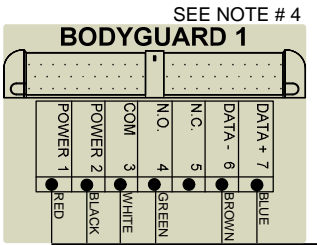
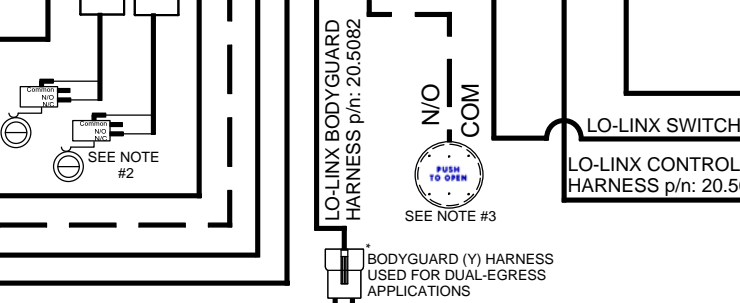
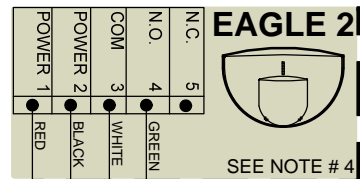
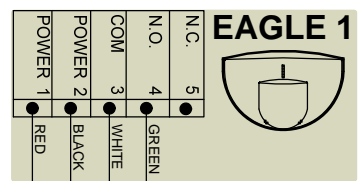
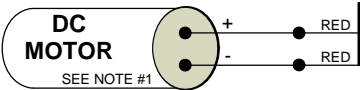
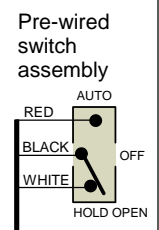
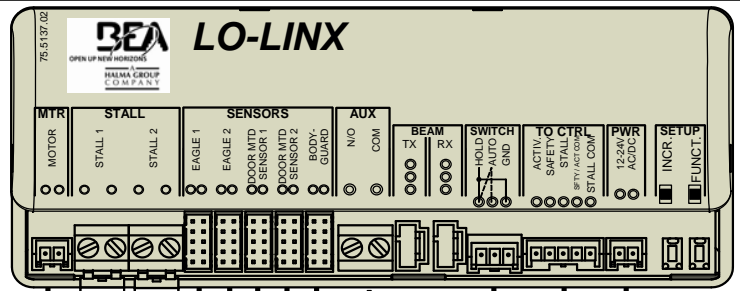

NOTES:

- MOTOR CONNECTION IS TIED IN PARALLEL TO EXISTING MOTOR LEADS. NO RESPECT TO PALARITY IS REQUIRED.
- EXTERNAL SWITCHES ARE REQUIRED IF INHIBIT DESIRED AT SWING SIDE SUPERSCANs, SWITCH OPENS UPON INHIBIT POINT.
- THE KNOWING ACT SWITCH IS CONNECTED AT THE AUX INPUT AND CAN BE ANY DRY CONTACT DEVICE SUCH AS A PUSHPLATE, CARD READER, ETC. THE AUX INPUT IS REQUIRED FOR ALL INITIAL ACTIVATION WHEN FUNCTION 'FA' ON THE LO-LINX IS SET TO '01'.
- THE SECOND BODYGUARD AND EAGLE ARE PRIMARILY USED IN DUAL-EGRESS APPLICATIONS. ENSURE BODYGUARD RELAY VALUE IS SET TO 2.
- BEA RECOMMENDS TO USE THE HUNTER SYNC BOARD TO SYNC 2 DOOR CONTROLS FOR A PAIR OR DOUBLE EGREES SET OF DOORS.

IF AFTER TROUBLESHOOTING A PROBLEM, A SATISFACTORY SOLUTION CANNOT BE ACHIEVED, PLEASE CALL B.E.A., INC. FOR FURTHER ASSISTANCE DURING EASTERN STANDARD TIME AT 1-800-523-2462 FROM 8AM - 5PM. FOR AFTER-HOURS, CALL EAST COAST: 1-866-836-1863 OR 1-800-407-4545 / MID-WEST: 1-888-308-8843 / WEST COAST: 1-888-419-2564. DO NOT LEAVE ANY PROBLEM UNRESOLVED. IF YOU MUST WAIT FOR THE FOLLOWING WORKDAY TO CALL B.E.A., LEAVE THE DOOR INOPERABLE UNTIL SATISFACTORY REPAIRS CAN BE MADE. NEVER SACRIFICE THE SAFE OPERATION OF THE AUTOMATIC DOOR OR GATE FOR AN INCOMPLETE SOLUTION.WEB: WWW.BEASENSORS.COM

OPEN UP NEW HORIZONS
A HALMA GROUP COMPANY

100 ENTERPRISE DRIVE
PITTSBURGH, PA 15275
PHONE: (412) 249-4100
FAX: (412) 249-4101
EMAIL: www.beasensors.com

TITLE: HUNTER LO-LINX SYSTEM

SIZE: A	DRAWN BY: JED	REV BY: TUC	PART NO: 80.0285.01
SCALE: NONE	DATE: 10/15/2007	SHEET 1 OF 1	

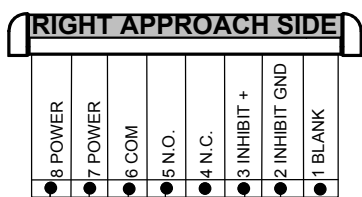
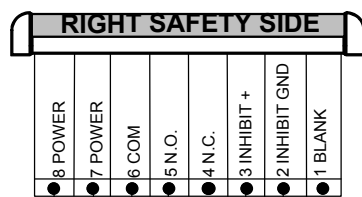
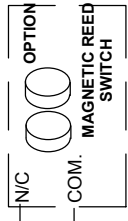
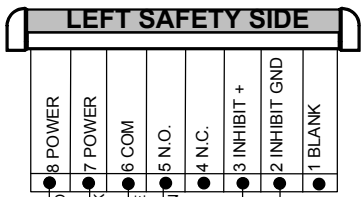
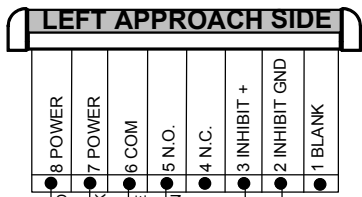

BODYGUARD

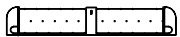

DK-12

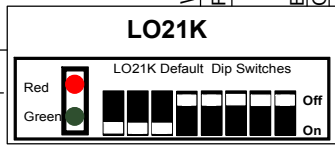
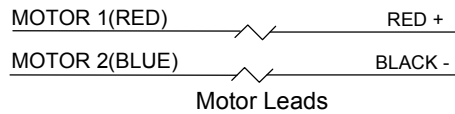
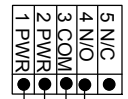
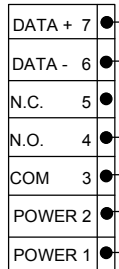
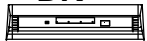

DIP SWITCHES 6, 7, 8 NOT USED

SUPERSCAN QUICK DISCONNECT CABLE

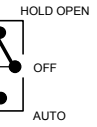

Activation
Activation RTN
Safety 1
Safety RTN
Safety 2
24VAC Out
24VAC Out
Ground
24VAC IN
24VAC IN

PRELIMINARY

- NOTES:
1. BEA RECOMMENDS TO USE THE HUNTER SYNC BOARD TO SYNC 2 DOOR CONTROLS WITH A PAIR OF DOORS.
 2. REMAINING WIRES ON LO21K NOT USED.
 3. IF USING THE OPTIONAL INHIBIT SWITCH ROUTE SAFETY SIDE SUPERSCAN N.O. IN SERIES THRU THE INHIBIT SWITCH.

BEA
We open up New Horizons
HALMA GROUP COMPANY

B.E.A., Inc.
100 Enterprise Drive Pittsburgh, PA 15275
PH: (412) 249-4100 FAX: (412) 249-4101
www.beasensors.com

Hunter Automatics FA Control, TYPE 09722A, LO21K, Parallax 2 Quick Disconnect on Approach

SIZE	CAGE CODE	DWG NO	FILE OF:	DRAWN BY:	REV
A		80.0222	JED	JED	
SCALE		DATE: 6 JUNE 24 2004		SHEET 1 OF 1	

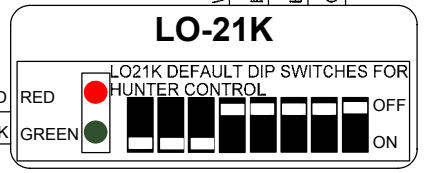
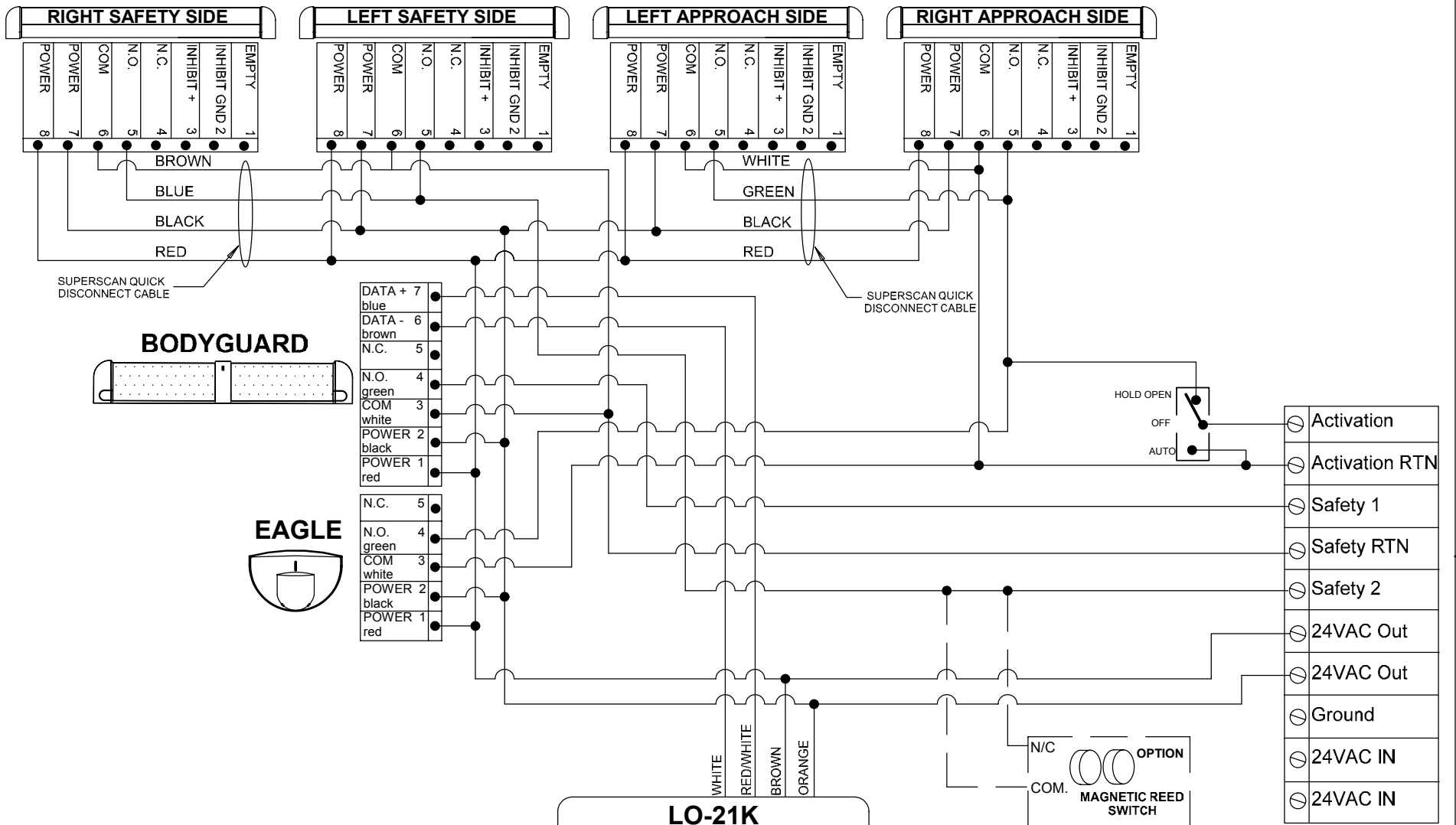

NOTES: 1) BEA RECOMMENDS TO USE THE HUNTER SYNC BOARD TO SYNC 2 DOOR CONTROLS WITH A PAIR OF DOORS.
 2) REMAINING WIRES ON LO21K NOT USED.
 3) IF USING THE OPTIONAL INHIBIT SWITCH ROUTE SAFETY SIDE SUPERSCAN N.O. IN SERIES THRU THE INHIBIT SWITCH.

IF AFTER TROUBLESHOOTING A PROBLEM, A SATISFACTORY SOLUTION CANNOT BE ACHIEVED, PLEASE CALL B.E.A., INC. FOR FURTHER ASSISTANCE DURING EASTERN STANDARD TIME AT 1-800-523-2462 FROM 8AM - 5PM. FOR AFTER-HOURS, CALL EAST COAST: 1-866-836-1863 OR 1-800-407-4545 / MID-WEST: 1-888-308-8843 / WEST COAST: 1-888-419-2564. DO NOT LEAVE ANY PROBLEM UNRESOLVED. IF YOU MUST WAIT FOR THE FOLLOWING WORKDAY TO CALL B.E.A., LEAVE THE DOOR INOPERABLE UNTIL SATISFACTORY REPAIRS CAN BE MADE. NEVER SACRIFICE THE SAFE OPERATION OF THE AUTOMATIC DOOR OR GATE FOR AN INCOMPLETE SOLUTION. WEB: WWW.BEASENSORS.COM

BEA
 We open up New Horizons
 HALMA GROUP COMPANY

100 ENTERPRISE DRIVE
 PITTSBURGH, PA 15275
 PHONE: (412) 249-4100
 FAX: (412) 249-4101
 EMAIL: www.beasensors.com

TITLE: Hunter Automatics FA Control, TYPE 09722A, LO21K, Parallax 2 Quick Disconnect on Safety			
SIZE: A	DRAWN BY: KJG	REV BY: TUC	PART NO: 80.0223.01
	SCALE: NONE	DATE: 08SEP2005	SHEET 1 OF 1



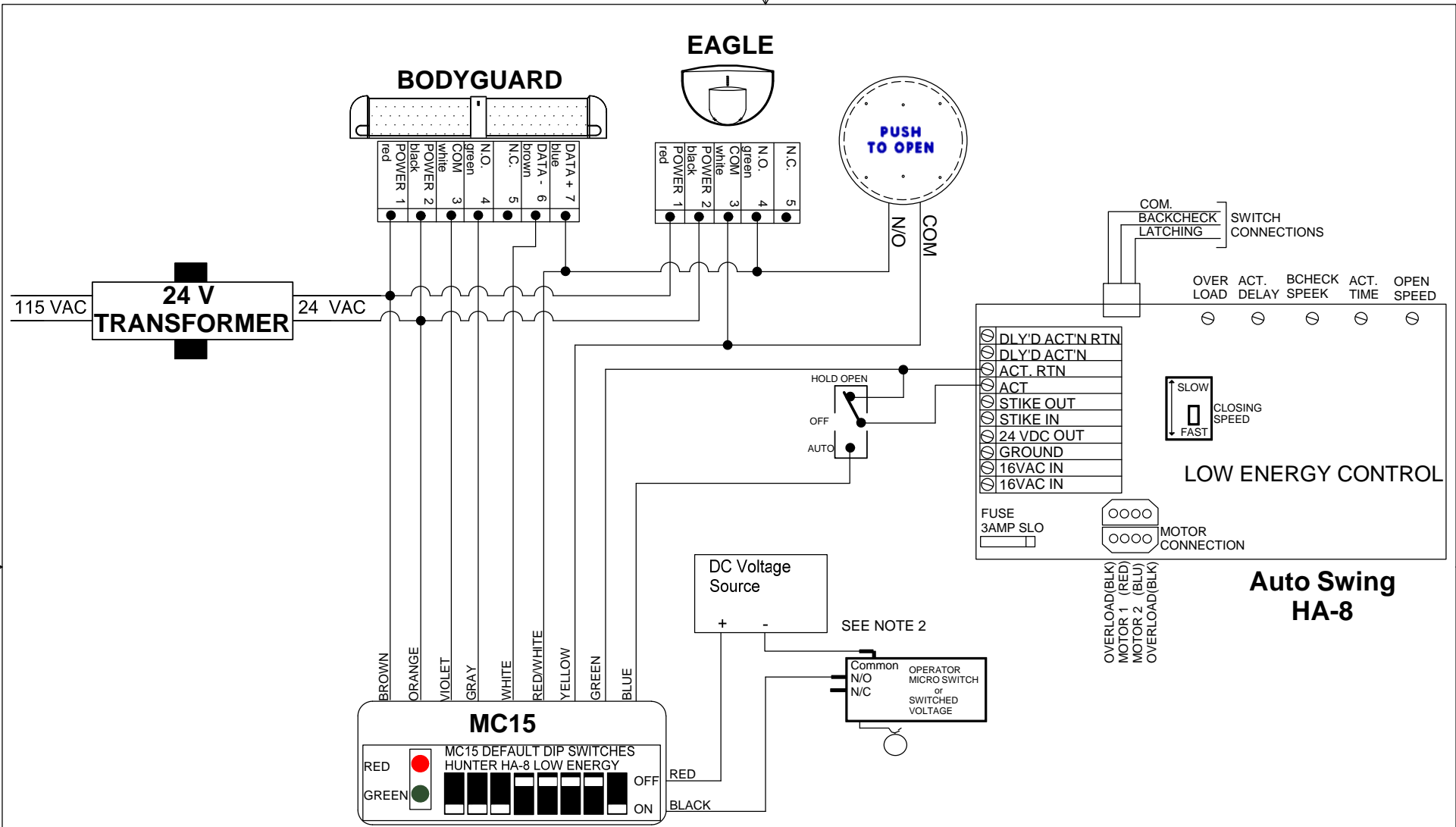

NOTES: 1) MC15 DIPSWITCHES: 1-5 (LOCK-OUT TIMING), 6,7,8, (NOT USED)
 2) OPERATOR MICRO SWITCH SHALL CLOSE AT APPROX. 85 DEGREES or 5 DEGREES LESS THAN FULL OPEN.

IF AFTER TROUBLESHOOTING A PROBLEM, A SATISFACTORY SOLUTION CANNOT BE ACHIEVED, PLEASE CALL B.E.A., INC. FOR FURTHER ASSISTANCE DURING EASTERN STANDARD TIME AT 1-800-523-2462 FROM 8AM - 5PM. FOR AFTER-HOURS, CALL EAST COAST: 1-866-836-1863 OR 1-800-407-4545 / MID-WEST: 1-888-308-8843 / WEST COAST: 1-888-419-2564. DO NOT LEAVE ANY PROBLEM UNRESOLVED. IF YOU MUST WAIT FOR THE FOLLOWING WORKDAY TO CALL B.E.A., LEAVE THE DOOR INOPERABLE UNTIL SATISFACTORY REPAIRS CAN BE MADE. NEVER SACRIFICE THE SAFE OPERATION OF THE AUTOMATIC DOOR OR GATE FOR AN INCOMPLETE SOLUTION. WEB: WWW.BEASENSORS.COM

BEA
 We open up New Horizons
 HALMA GROUP COMPANY
 100 ENTERPRISE DRIVE
 PITTSBURGH, PA 15275
 PHONE: (412) 249-4100
 FAX: (412) 249-4101
 EMAIL: www.beasensors.com

TITLE: HUNTER AUTOMATICS: AUTO SWING HA-8 MC15, BODYGUARD, EAGLE LOW ENERGY

SIZE: A	DRAWN BY: KJG	REV BY: WJR	PART NO: 80.0224.03
	SCALE: NONE	DATE: 07MAY2009	SHEET 1 OF 1

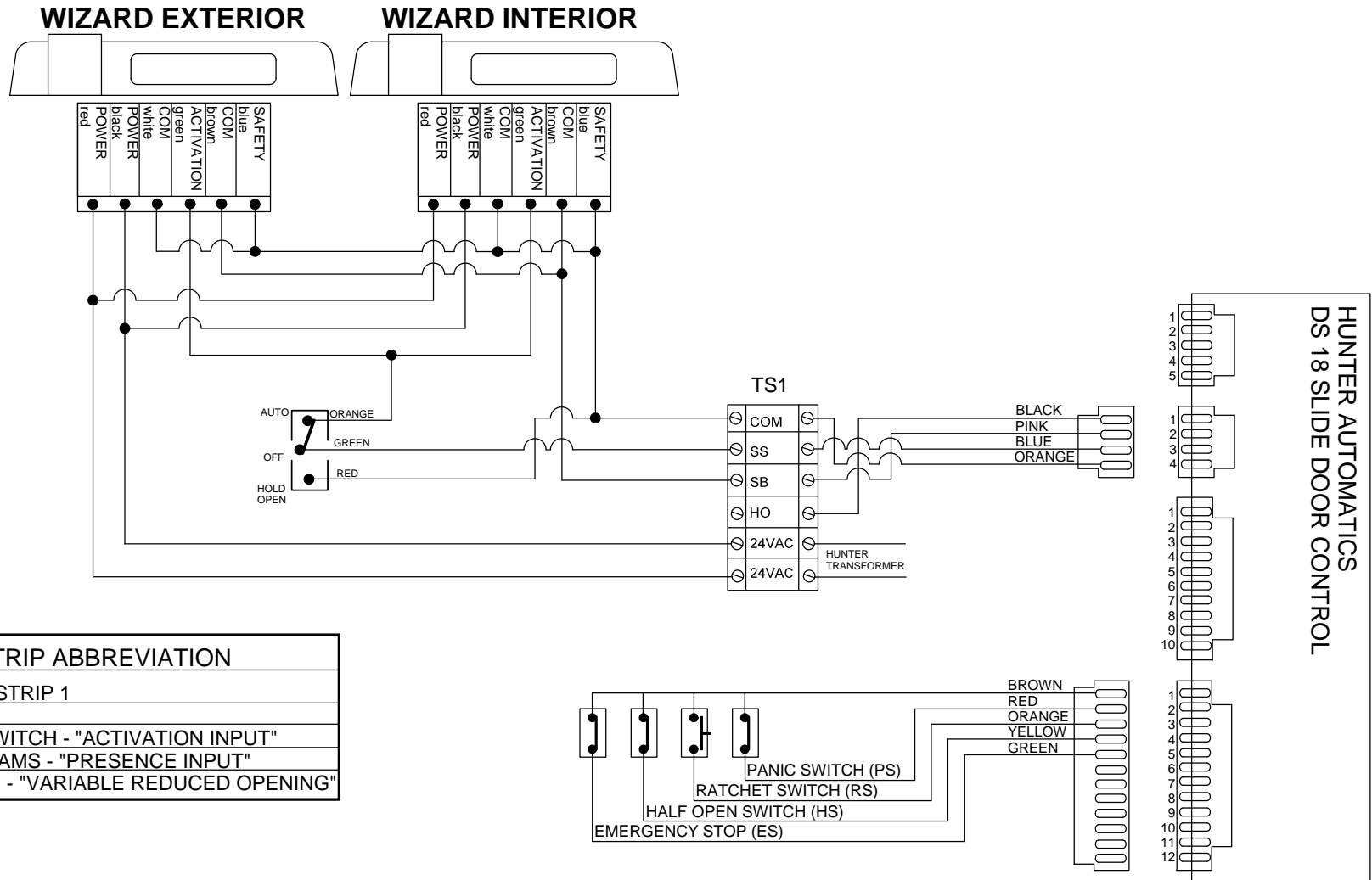

TERMINAL STRIP ABBREVIATION	
TS1	TERMINAL STRIP 1
COM	COMMON
SS	SENSOR SWITCH - "ACTIVATION INPUT"
SB	SAFETY BEAMS - "PRESENCE INPUT"
HO	HALF OPEN - "VARIABLE REDUCED OPENING"

NOTES:

1. CONNECT WIZARD BLUE & BROWN AS SHOWN.(REVERSED)
2. ENSURE THE CONTROL PARAMETER "DE" LED IS OFF FOR N.O. CIRCUIT.
3. IF WIRING THE SAFETY (SB) CIRCUIT N.C. ENSURE THE CONTROL PARAMETER "DE" LED IS ON. TERMINATE THE EXT. WIZARD BLUE TO THE INT. WIZARD BROWN.ROUTE THE EXT. WIZARD BROWN TO THE SB AND THE INT. WIZARD BLUE TO THE COMMON TERMINALS.
4. IF WIRING THE WIZARD BROWN & BLUE (PRESENCE) AS N.C. ENSURE TO CHANGE THE OUTPUT CONFIGERATION TO VALUE 1. (RELAY VALUE 1)
5. CONNECT RESPECTIVE WIZARD GREEN TO SWITCH NOT TERMINAL STRIP.

IF AFTER TROUBLESHOOTING A PROBLEM, A SATISFACTORY SOLUTION CANNOT BE ACHIEVED, PLEASE CALL B.E.A., INC. FOR FURTHER ASSISTANCE DURING EASTERN STANDARD TIME AT 1-800-523-2462 FROM 8AM - 5PM. FOR AFTER-HOURS, CALL EAST COAST: 1-866-836-1863 OR 1-800-407-4545 / MID-WEST: 1-888-308-8843 / WEST COAST: 1-888-419-2564. DO NOT LEAVE ANY PROBLEM UNRESOLVED. IF YOU MUST WAIT FOR THE FOLLOWING WORKDAY TO CALL B.E.A., LEAVE THE DOOR INOPERABLE UNTIL SATISFACTORY REPAIRS CAN BE MADE. NEVER SACRIFICE THE SAFE OPERATION OF THE AUTOMATIC DOOR OR GATE FOR AN INCOMPLETE SOLUTION.WEB: WWW.BEASENSORS.COM

		100 ENTERPRISE DRIVE PITTSBURGH, PA 15275 PHONE: (412) 249-4100 FAX: (412) 249-4101 EMAIL: www.beasensors.com	
TITLE: HUNTER AUTOMATICS DS 18 WIZARDS, 3-POS. SWITCH			
SIZE:	DRAWN BY:	REV BY:	PART NO:
A	KJG	EOF	80.0290.00
	SCALE:	DATE:	SHEET
	NONE	13, DEC. 2007	1 OF 1

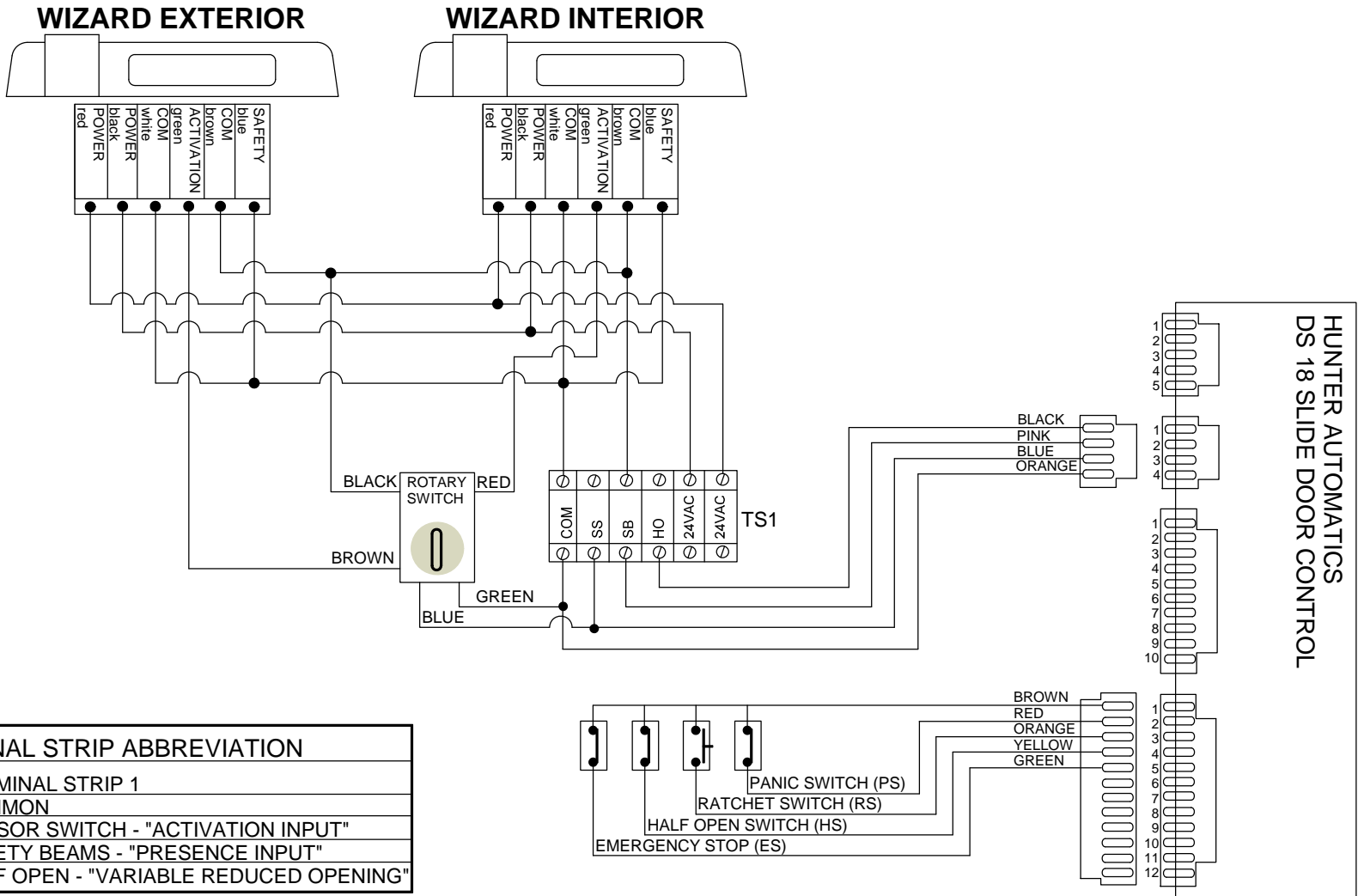

TERMINAL STRIP ABBREVIATION	
TS1	TERMINAL STRIP 1
COM	COMMON
SS	SENSOR SWITCH - "ACTIVATION INPUT"
SB	SAFETY BEAMS - "PRESENCE INPUT"
HO	HALF OPEN - "VARIABLE REDUCED OPENING"

NOTES:

1. CONNECT WIZARD BLUE & BROWN AS SHOWN.(REVERSED)
2. ENSURE THE CONTROL PARAMETER "DE" LED IS OFF FOR N.O. CIRCUIT.
3. IF WIRING THE SAFETY (SB) CIRCUIT N.C. ENSURE THE CONTROL PARAMETER "DE" LED IS ON. TERMINATE THE EXT. WIZARD BLUE TO THE INT. WIZARD BROWN.ROUTE THE EXT. WIZARD BROWN TO THE SB AND THE INT. WIZARD BLUE TO THE COMMON TERMINALS.
4. IF WIRING THE WIZARD BROWN & BLUE (PRESENCE) AS N.C. ENSURE TO CHANGE THE OUTPUT CONFIGERATION TO VALUE 1. (RELAY VALUE 1)
5. CONNECT RESPECTIVE WIZARD GREEN TO SWITCH NOT TERMINAL STRIP.

IF AFTER TROUBLESHOOTING A PROBLEM, A SATISFACTORY SOLUTION CANNOT BE ACHIEVED, PLEASE CALL B.E.A., INC. FOR FURTHER ASSISTANCE DURING EASTERN STANDARD TIME AT 1-800-523-2462 FROM 8AM - 5PM. FOR AFTER-HOURS, CALL EAST COAST: 1-866-836-1863 OR 1-800-407-4545 / MID-WEST: 1-888-308-8843 / WEST COAST: 1-888-419-2564. DO NOT LEAVE ANY PROBLEM UNRESOLVED. IF YOU MUST WAIT FOR THE FOLLOWING WORKDAY TO CALL B.E.A., LEAVE THE DOOR INOPERABLE UNTIL SATISFACTORY REPAIRS CAN BE MADE. NEVER SACRIFICE THE SAFE OPERATION OF THE AUTOMATIC DOOR OR GATE FOR AN INCOMPLETE SOLUTION.WEB: WWW.BEASENSORS.COM



100 ENTERPRISE DRIVE
PITTSBURGH, PA 15275
PHONE: (412) 249-4100
FAX: (412) 249-4101
EMAIL: www.beasensors.com

**TITLE: HUNTER AUTOMATICS DS 18
WIZARD, 4- POS. ROTARY SWITCH**

SIZE:	DRAWN BY:	REV BY:	PART NO:
A	KJG	EOF	80.0291.00
	SCALE:	DATE:	SHEET
	NONE	13, DEC. 2007	1 OF 1

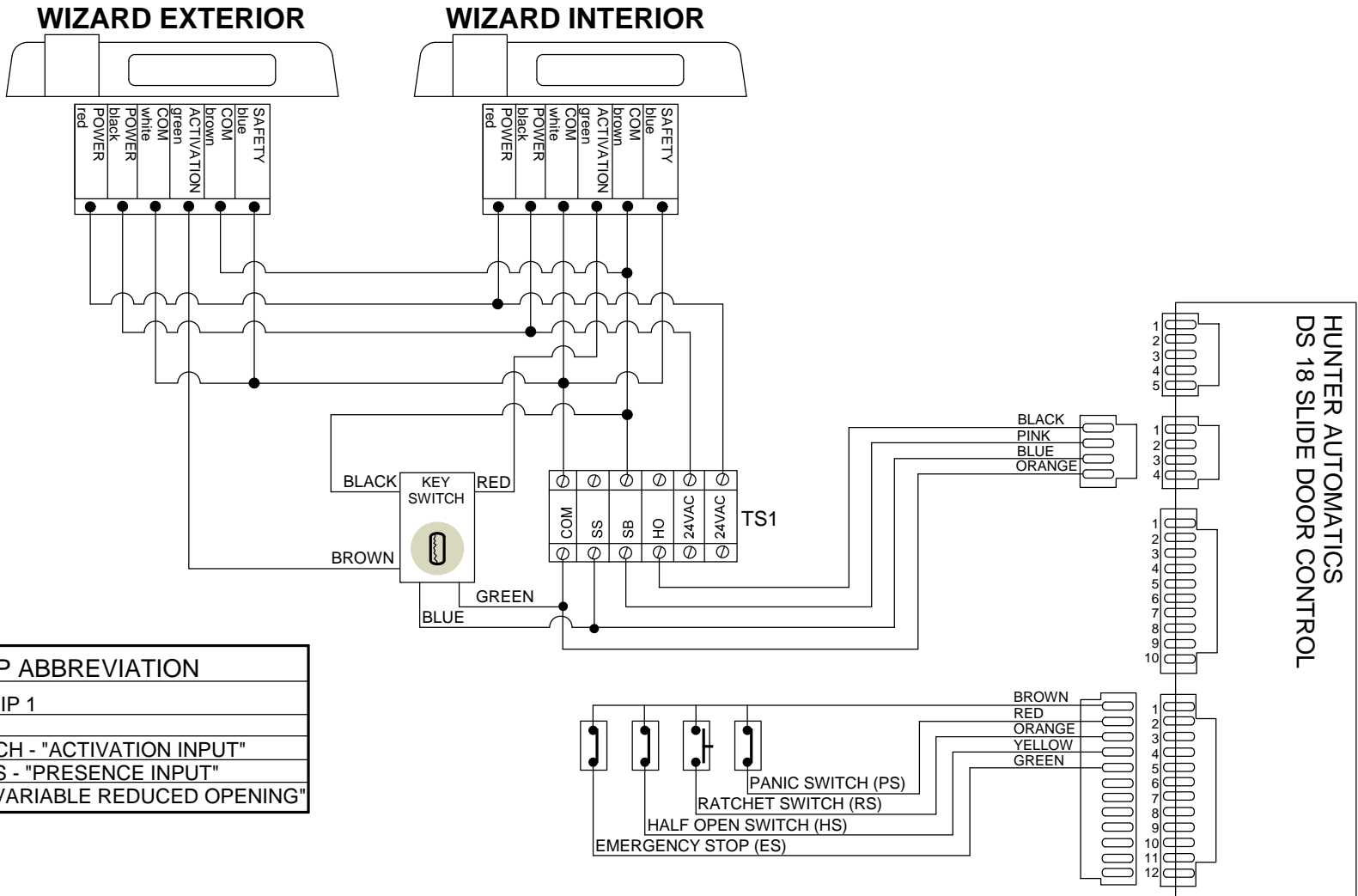

TERMINAL STRIP ABBREVIATION	
TS1	TERMINAL STRIP 1
COM	COMMON
SS	SENSOR SWITCH - "ACTIVATION INPUT"
SB	SAFETY BEAMS - "PRESENCE INPUT"
HO	HALF OPEN - "VARIABLE REDUCED OPENING"

NOTES:

1. CONNECT WIZARD BLUE & BROWN AS SHOWN.(REVERSED)
2. ENSURE THE CONTROL PARAMETER "DE" LED IS OFF FOR N.O. CIRCUIT.
3. IF WIRING THE SAFETY (SB) CIRCUIT N.C. ENSURE THE CONTROL PARAMETER "DE" LED IS ON. TERMINATE THE EXT. WIZARD BLUE TO THE INT. WIZARD BROWN.ROUTE THE EXT. WIZARD BROWN TO THE SB AND THE INT. WIZARD BLUE TO THE COMMON TERMINALS.
4. IF WIRING THE WIZARD BROWN & BLUE (PRESENCE) AS N.C. ENSURE TO CHANGE THE OUTPUT CONFIGERATION TO VALUE 1. (RELAY VALUE 1)
5. CONNECT RESPECTIVE WIZARD GREEN TO SWITCH NOT TERMINAL STRIP.

IF AFTER TROUBLESHOOTING A PROBLEM, A SATISFACTORY SOLUTION CANNOT BE ACHIEVED, PLEASE CALL B.E.A., INC. FOR FURTHER ASSISTANCE DURING EASTERN STANDARD TIME AT 1-800-523-2462 FROM 8AM - 5PM. FOR AFTER-HOURS, CALL EAST COAST: 1-866-836-1863 OR 1-800-407-4545 / MID-WEST: 1-888-308-8843 / WEST COAST: 1-888-419-2564. DO NOT LEAVE ANY PROBLEM UNRESOLVED. IF YOU MUST WAIT FOR THE FOLLOWING WORKDAY TO CALL B.E.A., LEAVE THE DOOR INOPERABLE UNTIL SATISFACTORY REPAIRS CAN BE MADE. NEVER SACRIFICE THE SAFE OPERATION OF THE AUTOMATIC DOOR OR GATE FOR AN INCOMPLETE SOLUTION.WEB: WWW.BEASENSORS.COM

		100 ENTERPRISE DRIVE PITTSBURGH, PA 15275 PHONE: (412) 249-4100 FAX: (412) 249-4101 EMAIL: www.beasensors.com	
TITLE: HUNTER AUTOMATICS DS 18 WIZARD, 4- POS. KEY SWITCH			
SIZE:	DRAWN BY:	REV BY:	PART NO:
A	KJG	EOF	80.0292.00
	SCALE:	DATE:	SHEET
	NONE	13, DEC. 2007	1 OF 1