

ALL CONNECTIONS ARE PARALLELED AT CONTROL
CAP OFF BLUE, YELLOW AND ORANGE IF NOT USED.

ORANGE AND BLUE MAY BE USED TO INHIBIT
SAFETYSIDE SUPERSCAN. CAP OFF AT CTRL.
IF NOT USED. SEE SUPERSCAN Q.D. USERS GUIDE
FOR MORE INFO ON INHIBITING SYPERSCAN.

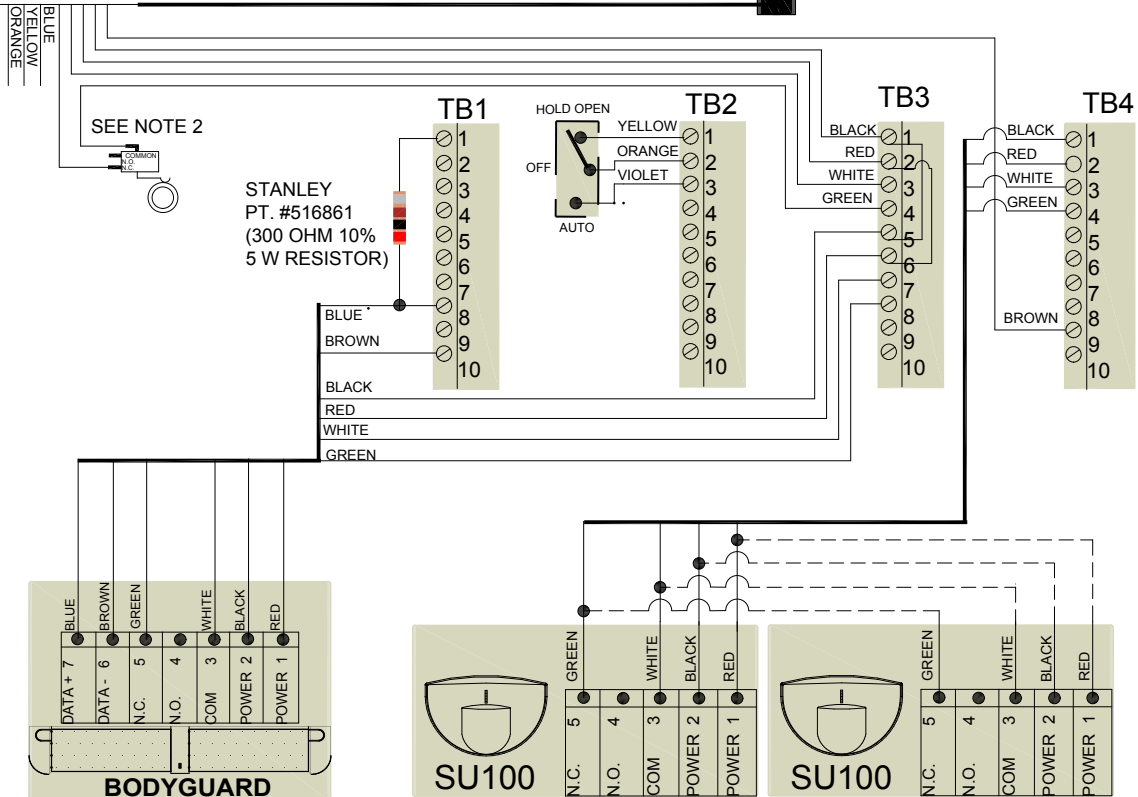

MC521	TB-1	TB-2	TB-3	TB-4	TB-5
1)	CONN. RESISTOR FROM 1 TO 8	HOLD OPEN	12VAC	12VAC	12VAC
2)		COMMON	12VAC	12VAC	12VAC
3)		AUTOMATIC	COMMON	COMMON	
4)			STALL	OPERATE	
5)			12VAC	12VAC	12VAC
6)			12VAC	12VAC	12VAC
7)			COMMON	COMMON	HOLD BEAM
8)	BODY GUARD DATA POSITIVE		SAFETY	SAFETY	COMMON
9)	BODY GUARD DATA NEGATIVE		BREAK OUT	PUSH PLATE	
10)			COMMON	COMMON	

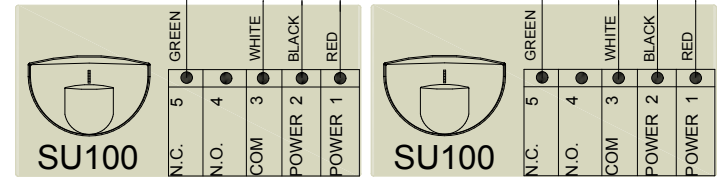
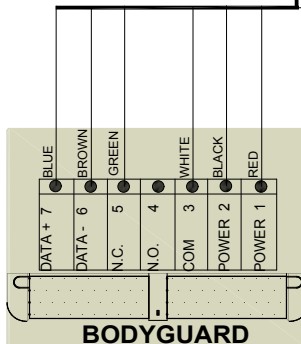
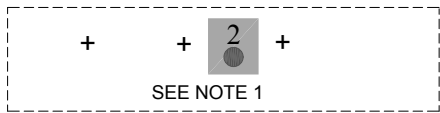

- NOTE 1) WHEN WIRED AS SHOWN SET BODY GUARD OUT PUT CONFIGURATION TO 2 WITH BEA REMOTE.
 2) IF NECESSARY, USE AUXILIARY SWITCH ON OPERATOR TO INHIBIT SAFETY SIDE SUPER SCANS SWITCH SHOULD OPEN AT APPROXIMATELY 65 DEGREES.
 3) IF USING BEA EAGLES SET RELAY CONFIGURATION TO 2 WITH BEA REMOTE.
 4) FOR MORE INFORMATION ON THE STANLEY MC521 CONTROL SEE MANUAL 204027.
 5) FOR DUAL EGRESS WITH SECOND BODY GUARD USE DUAL EGRESS Y-HARNES BEA PT # 20.5083 REFER TO BODY GUARD USERS GUIDE PAGE 5 FOR PROPER ADJUSTMENT PROCEDURE.

SEE NOTE 3

IF AFTER TROUBLESHOOTING A PROBLEM, A SATISFACTORY SOLUTION CANNOT BE ACHIEVED, PLEASE CALL B.E.A., INC. FOR FURTHER ASSISTANCE DURING EASTERN STANDARD TIME AT 1-800-523-2462 FROM 8AM - 5PM. FOR AFTER-HOURS, CALL EAST COAST: 1-866-836-1863 OR 1-800-407-4545 / MID-WEST: 1-888-308-8843 / WEST COAST: 1-888-419-2564. DO NOT LEAVE ANY PROBLEM UNRESOLVED. IF YOU MUST WAIT FOR THE FOLLOWING WORKDAY TO CALL B.E.A., LEAVE THE DOOR INOPERABLE UNTIL SATISFACTORY REPAIRS CAN BE MADE. NEVER SACRIFICE THE SAFE OPERATION OF THE AUTOMATIC DOOR OR GATE FOR AN INCOMPLETE SOLUTION. WEB: WWW.BEASENSORS.COM

100 ENTERPRISE DRIVE
PITTSBURGH, PA 15275
PHONE: (412) 249-4100
FAX: (412) 249-4101
EMAIL: www.beasensors.com

TITLE: STANLEY MC521 - PARALLAX II Q.D. ON SAFETY SIDE

SIZE:	DRAWN BY: WJR	REV BY: WJR	PART NO: 80.0311.01
A	SCALE: NONE	DATE: 08 NOV. 2011	SHEET 1 OF 1

