



BODYGUARD PRESENCE DETECTOR INSTRUCTION MANUAL

We can be reached from anywhere in the world:
US & Canada Toll Free 800-523-2462 (EST)
US & Canada Toll Free 877-232-9378 (PST)
Mexico Toll Free 001-800-711-1398
Latin America 412-782-5191
Email: sales@beainc.com

B.E.A., Inc. • 300 South Main Street • Pittsburgh PA 15215 • USA
Tel. 412-782-5150 • Fax 412-782-5154

This manual may be downloaded from our web site in PDF format: www.beainc.com
Requires Adobe Acrobat Reader.

75.0085 V5 April 2000

TABLE OF CONTENTS

INTRODUCTION - BODYGUARD QUICK REFERENCE GUIDE	3
INSTALLATION.....	3
SET-UP	3
PROGRAM.....	3
BODYGUARD PROGRAMMING “CHEAT SHEET”	4
BODYGUARD PRESENCE SENSOR – PRODUCT SPECIFICATION	5
BODYGUARD TECHNICAL SPECIFICATIONS	5
INSTALLATION PROCEDURES	6
SETTING THE DETECTOR ANGLE	7
WIRING DIAGRAM.....	8
SETTING UP THE BODYGUARD USING THE UNIVERSAL REMOTE	9
CHANGING THE ACCESS CODE FOR THE BODYGUARD.....	10
NON-REMOTE SETUP	11
BODYGUARD PATTERN CHARTS	12
BODYGUARD TROUBLESHOOTING	15

OBSOLETE

INTRODUCTION - BODYGUARD QUICK REFERENCE GUIDE

B.E.A. recommends reading through this guide prior to your installation. We have designed this quick reference to help you while you are in the field. *This is not to replace your Bodyguard Instruction Manual.*

B.E.A. has programmed the Bodyguard to have factory default settings. They are defined in the following steps.

REMEMBER! If at any time the factory defaults are appropriate for your application, you **do not** have to change them. Only change the parameters that are needed for your application.

INSTALLATION





- **POSITION THE BODYGUARD AT THE BOTTOM OF THE HEADER ON SWING SIDE OF THE DOOR.**
- Utilize LO-21, LO-21S, or MC-15 to achieve 2 position (door open and door closed) set-up.
- Utilize the Bodyguard Mounting Block (Body Mount) when your doors are loose and partially open due to stack pressure or wind. Also use Body Mount if you are also installing SuperScan sticks with offset pivot or hinges.

B O D Y G U A R D	PWR	1	□
	PWR	2	□
	COM	3	□
	NO	4	□
	NC	5	□
	DATA-	6	□
	DATA+	7	□









SET-UP

- The Bodyguard will automatically learn the door closed position after it is initially powered up. Then activate the door so the Bodyguard will learn the door in the open position. Remain out of the threshold area of the door while the Bodyguard is in the door open set-up procedure.

PROGRAM

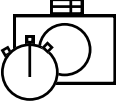
- Point the remote control towards the sensor (the receiver is located inside of Bodyguard).
- Start your programming phase by pressing the Unlock button . The Bodyguard has a 4-digit access code to prevent undesired operation. The code is factory preset to 0000. If you are using the 0000 code, you will not have to enter the 4-digit code into the remote. You can begin programming immediately after pressing the  button.
- You must then press a function button, followed by a numerical value.
- After making all of the necessary changes in the open door position, press the Lock button  twice or the Lock button  followed by the access code. This is necessary to save the programming session. If a change to the sensing pattern has been made, the Bodyguard will automatically begin a learn set-up and flash green for approximately 10 seconds. It is then necessary to repeat these procedures for the door closed position.
- The only parameters that can be changed in the door open and door closed position are pattern width, pattern depth and sensitivity. All other parameters will be the same in both the door open and door closed positions. For example, if you press the relay button  and number 1, it will be the same in both door open and door closed positions.

BODYGUARD PROGRAMMING "CHEAT SHEET"

FUNCTION BUTTONS	ACTIONS	FACTORY SETTINGS
 SENSITIVITY	Press this key followed by the number button (0-9) of the sensitivity desired. 0 = minimum 9 = maximum	Door closed = 8 Door open = 8
 RELAY HOLD TIME	Press this key followed by the number button (0-9) to enter the required hold time. 0 = 1 second 1 = 2 seconds 2 = 3 seconds 3 = 4 seconds 4 = 5 seconds 5 = 6 seconds 6 = 7 seconds 7 = 8 seconds 8 = 9 seconds 9 = 10 seconds	1 second = 0
 PATTERN SELECTION	Press this key followed by a number button (1-9) to select the required pattern. Different settings can be selected for both positions of the door, DOOR OPEN or DOOR CLOSED. 1. Wide pattern 2. Middle pattern 3. Asymmetric left narrow 4. Asymmetric right 5. Narrow left 6. Narrow right 7. Asymmetric left wide 8. Asymmetric right wide 9. Center narrow	Door closed = 1 Door open = 2
 RELAY MODE	Press this key followed by a number button (1-4) to select the required relay output desired. 1- Passive* output , relay contact closed during detection, open during non-detection 2- Active** output , relay contact open during detection, closed during non-detection 3- Continuous detection , relay contact always closed 4- Continuous non-detection , relay contact always open	Passive = 1
 AUTO LEARN TIME	Press this key followed by a number button (0-9) to select the required auto-learn time. 0 = 30 seconds 1 = 1 minute 2 = 2 minutes 3 = 3 minutes 4 = 5 minutes 5 = 7 minutes 6 = 10 minutes 7 = 15 minutes 8 = 20 minutes 9 = 25 minutes	30 sec = 0
 FREQUENCY	Press this key followed by a number button (1-2) to select the required frequency. 1 = normal frequency 2 = random frequency 1 3 = random frequency 2	Random frequency 1 = 2
 INQUIRY	Press this button after pressing a function button. Then count the number of times the LED flashes. This corresponds to the status of the parameter in question.	No setting
 MAGIC WAND	Press this button followed by a number button (4 only) to launch the desired set-up. 3 = Automatic set-up 4 = Reset to factory default settings	No setting
 PATTERN DEPTH	Press this button followed by a number button (1-3) to choose your desired pattern depth. 1 – deep pattern 2 – medium pattern 3 – limited pattern	Door closed = 1 Door open = 1

***Passive Output:** This means that the NO-COM circuit is closed and the NC-COM circuit is open.

****Active Output:** This means that the NC-COM circuit is closed and the NO-COM circuit is open.

BODYGUARD PRESENCE SENSOR – PRODUCT SPECIFICATION

The B.E.A. Bodyguard Presence Sensor is an overhead-mounted diffused active infrared sensing device that provides detection for the triggering of automatic door safety functions. Applications include swinging, sliding, bifolding and low-energy door operation.

This sensor is designed for use with a B.E.A. LO-21, LO-21S, MC-15 or SS-21. When used with B.E.A.'s lockout devices, the sensor is programmed to allow two different fields of detection - one for detection when the door is in the fully closed position, and one for detection when the door is in the fully open position. While the door is in the fully open position, the Bodyguard extends its coverage beyond the threshold area of the doorway, to allow coverage that will overlap that of B.E.A.'s motion sensors, including the B.E.A. Eagle.

As with all of B.E.A.'s programmable sensing devices, full adjustability is achieved with the use of B.E.A.'s universal hand-held remote control unit. This allows alteration of all of the available functions as well as checking existing settings. Should the need arise, the Bodyguard may also be tuned by means of two sensor-mounted buttons contained on the PC Board within the unit. With these two buttons, the Bodyguard's field of detection can be altered without the use of the hand-held remote (please see page 11).

Package Contents:

- (1) Bodyguard Presence Sensor
- (1) 6' Power Cable (6 conductor)
- (2) Phillips head Mounting Screws
- (1) Instruction Manual

BODYGUARD TECHNICAL SPECIFICATIONS

Installation Height - Variable	9'-0" max. (recommended 6'-6" to 8'-0")
Mounting Angles Bodyguard only	+5°, +10° (factory default setting: +5°)
Bodyguard with Bodymount	0°, +5°, +10°
Power Supply	24 V AC / DC +/- 10%
Frequency	50-60 Hz
Output	Max. Voltage at contacts: 60V DC / 125V AC Max. current at contacts: 1 A (Resistor) Max. power supply: 30 W (DC), 120V (AC)
Relay Hold Time	1 to 10 seconds
Operating Temperature	-22°F to +140°F
Immunity	Immune to electrical and radio frequency interference
Cable	6'- six conductor cable
Weight	1lb. 11 oz. (765g)
Dimensions	11.8"L (305 mm.) x 1.9"H (51 mm.) x 1.9"W (46 mm.)
Material	Aluminum & ABS plastic
Housing Color	Black anodized aluminum

INSTALLATION PROCEDURES

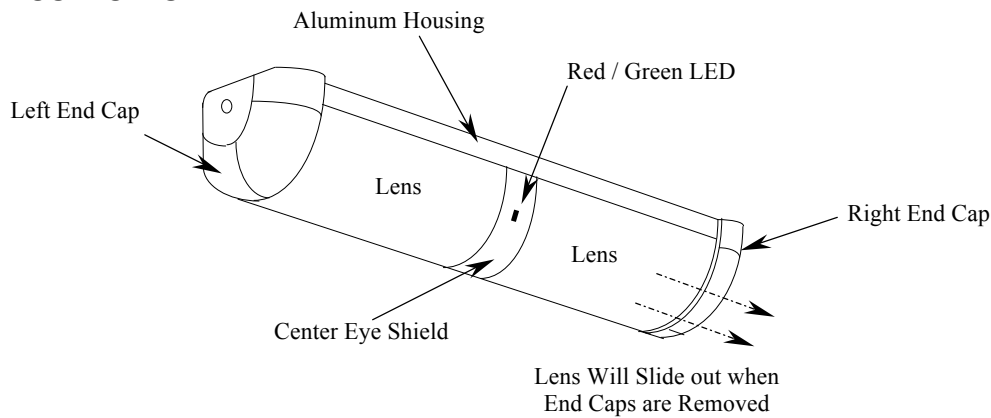

I. Disassembly of Bodyguard for installation

- a. Remove left & right end caps - set aside
- b. Slide the 2 lenses out - set aside.
- c. Remove center eye-shield - set aside
- d. Remove PCB Board - set aside

II. Attaching Body Mount and Bodyguard Sensor to Header

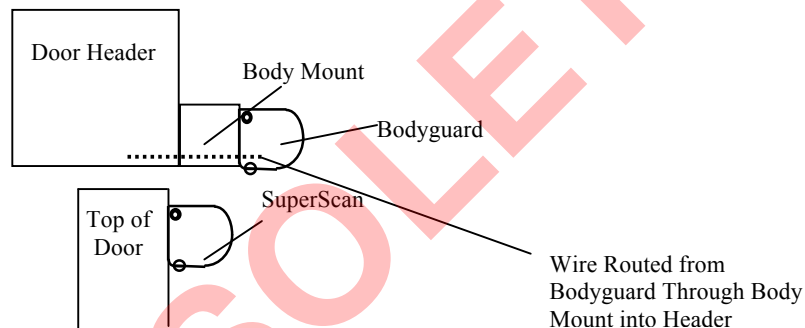

The optional Body Mount shown above is used to allow the Bodyguard sensor to stand off from the door header by 3". This ensures that the detection field from the Bodyguard will not be obstructed by the SuperScan door-mounted sensor or by slight door movement caused by such adverse conditions as stack pressure within a building. To install this mounting block, perform the following:

1. The optional Bodyguard Mounting Block should be positioned so that the 3" bottom of the extrusion is flush with the bottom edge of the door header, and centered within the door opening width. Once positioned, drill the holes in header with 1/8" drill bit. Note - the front of the mount block is the side that has 4 holes in it. The 2 large 1/2" holes are screwdriver access holes provided for ease of installation. Please see the diagram on the next page for dimensions.
2. Pre-drill the two - 2 1/8" holes with a 1/8" drill bit by reaching the bit through the 1/2" hole and aligning with 1/8" holes at the backside of the unit.
3. Once holes are drilled, attach the Bodyguard to the mounting block with the 2 Tek screws (provided). Again, the 1/2" holes are provided to allow a screwdriver and a mounting screw to reach through to the back mounting holes.
4. Attach the Bodyguard sensor to the mounting block with the two screws provided with the sensor.

IMPORTANT NOTE: The Body Mount does not need to be used if the reveal distance between face of door (or SuperScan - if used) and mounting surface for the Bodyguard is already greater than or equal to 3".

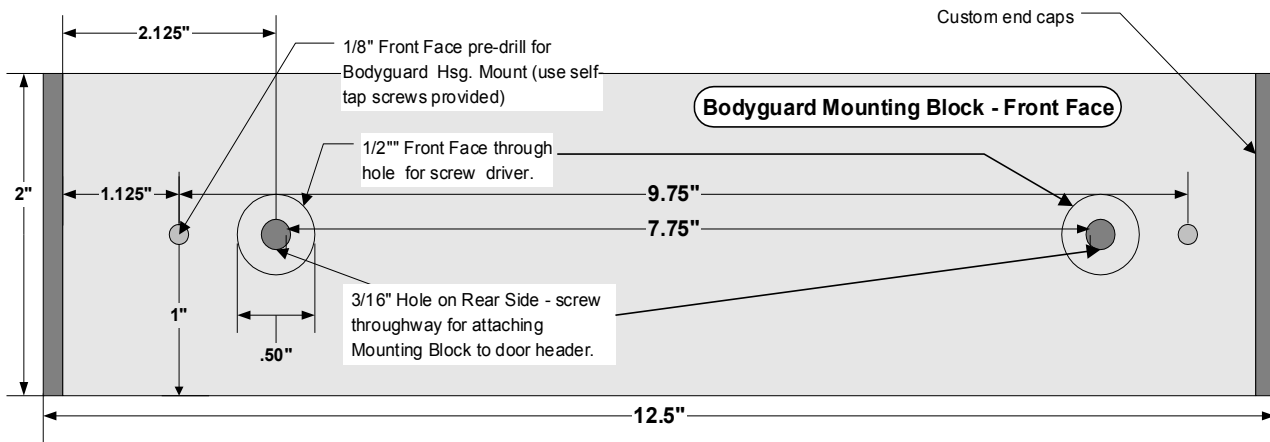

III. Provide Access Hole for Wire Routing Between Bodyguard Wire Terminal and Header

On the left side end cap, remove the breakaway tab that is on the backside of the cap. This will allow the wire to pass from the Bodyguard to the header. Then hold the end cap up to the header and mark the area right next to the breakaway tab. Drill a 1/4" hole in the header. This hole will allow wire passage and be concealed when end cap is in place.

SETTING THE DETECTOR ANGLE

**- CAUTION -
REMOVE TERMINAL BLOCK OR REMOVE POWER FROM BODYGUARD
BEFORE PROCEEDING WITH ANGLE ADJUSTMENT**

The Bodyguard's PCB is factory preset at a 5° angle from the floor surface, however if coverage is necessary further away from the threshold, the angle can be changed 10°. The 0° setting is only to be used when attaching the Bodyguard to the Bodymount to achieve greater threshold protection.

In order to change in the angle of detection, perform the following:

Remove both end caps, lenses and center eye shield. Remove one mounting screw - does not matter which side - slide out the PCB and the white clips. Once this is accomplished, spread the white clips and re-adjust them to a different angle. Once angle is set, re-insert the PCB and the white clips back into the aluminum housing and re-install the mounting screw. The PCB may be also be removed by prying the bottom of the clip outward as shown below.

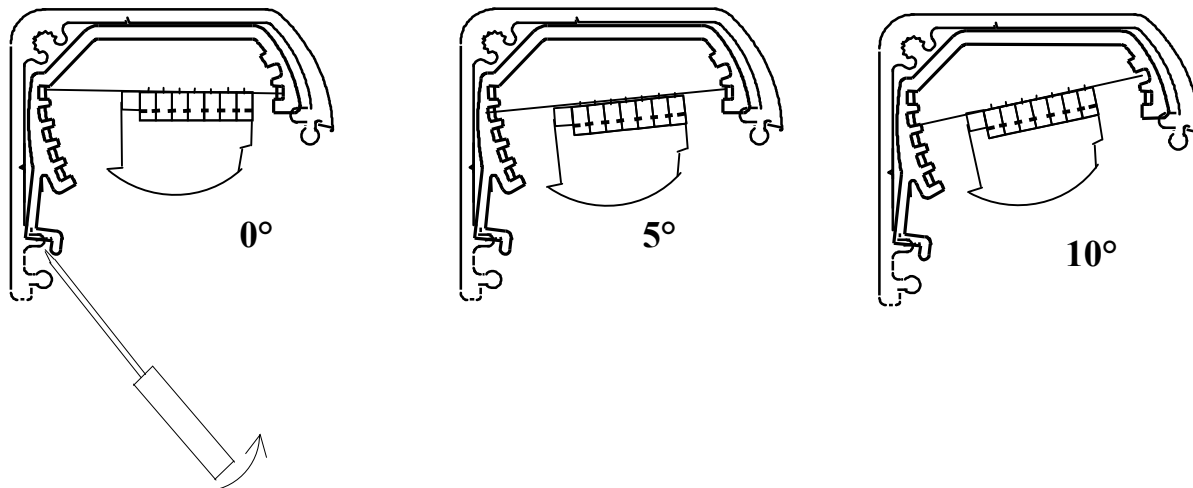

IV. Wiring Connections

Route the 6-wire cable (provided) from the door control to the Bodyguard terminal block at the left side of the sensor. Wiring can begin from the Bodyguard or the door control. In either case, be absolutely certain that no power is applied to any wires until all wiring and connections are complete and the sensor is ready to be powered up and tuned.

With the terminal block properly installed at the left side of the sensor, terminal #1 will be farthest from the mounting surface and the screws for the terminals will be facing down. It has the same plug connector as the DK-12 but the terminal connections are reversed. The terminal block may be pulled out to allow ease of wiring.

⊕ 1	24 V AC
⊕ 2	24 V AC
⊕ 3	COM
⊕ 4	NO
⊕ 5	NC
⊕ 6	Data (-)
⊕ 7	Data (+)

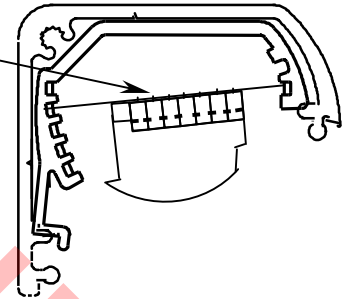

Once all wiring is complete, the lenses and center eye shield may be installed. Note, leave the end caps off until programming is complete in case the adjustment angle has to be altered. Proceed with powering up and tuning as follows.



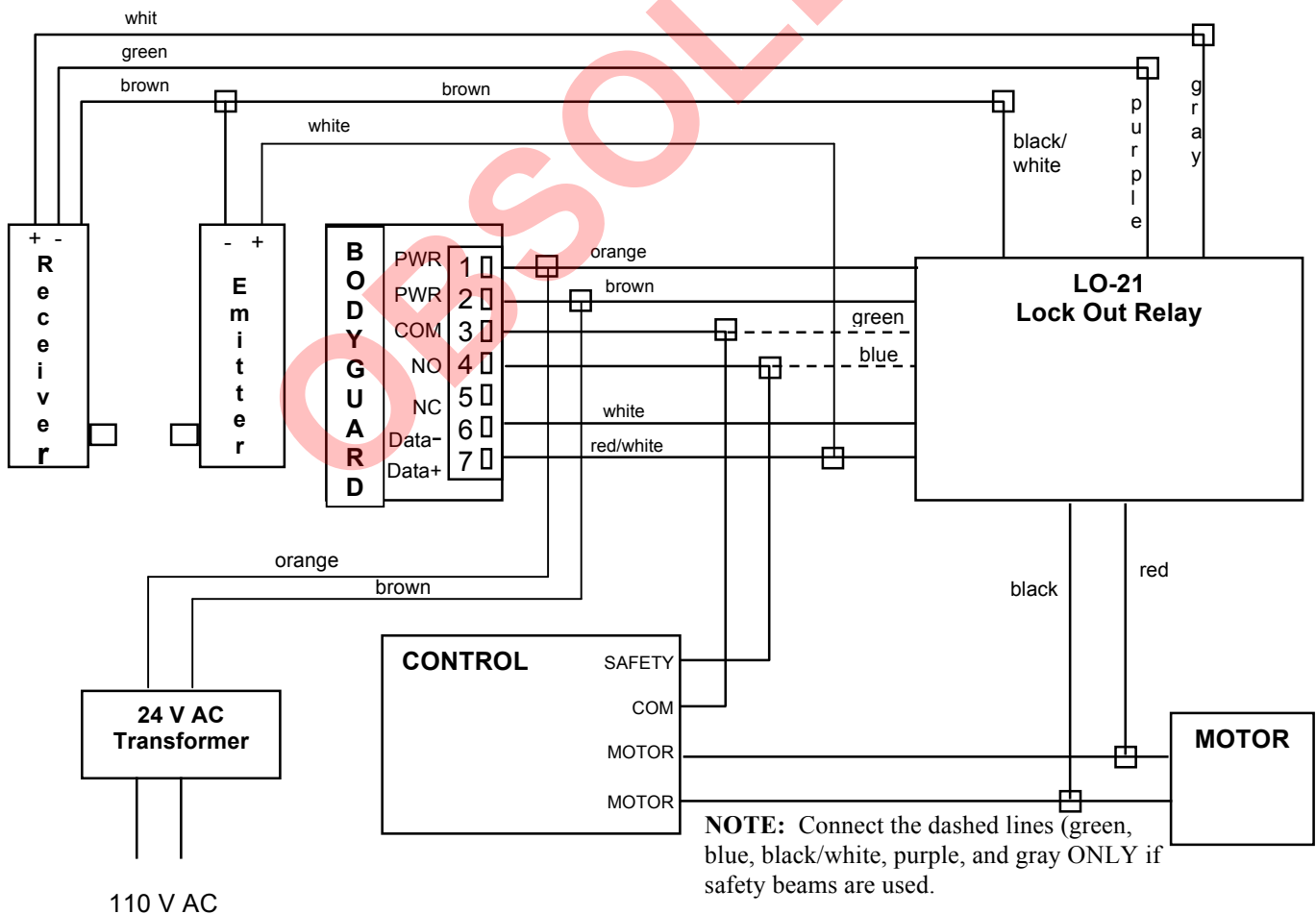

WIRING DIAGRAM



SETTING UP THE BODYGUARD USING THE UNIVERSAL REMOTE

The Bodyguard will automatically learn the door in the closed position after it is initially powered up. You must then activate the door so the Bodyguard will learn the door in the open position.

1. INQUIRE ABOUT A SETTING

- First press the unlock button  on the remote to unlock the sensor. Then enter the access code if the default code has been changed.
- Press the desired function button followed by the Inquiry  button. The green LED on the Bodyguard will flash a number of times, indicating the current function's setting.
- For example, press the sensitivity button  followed by Inquiry  button. The green LED will flash 8 times.

2. CHANGE A SETTING

- After unlocking the sensor, select the desired function button followed by a number. Refer to the cheat sheet on page 3 for assistance.
- After the function button is pressed, the red LED will flash rapidly (+/- 10Hz). 30 seconds will be given to make a numerical choice. If a number is not entered within the 30 seconds the Bodyguard will go back into Lock mode and keep the default setting.
- For example, press the Auto Learn Time Button  followed by number 2. The Learn Time will then be set for 2 minutes.
- Once you are finished programming the Bodyguard, you must then store the changes into permanent memory so they are retained if there is a power loss.

3. SAVING CHANGES

- Press the lock button  twice. The red LED will flash at a rate of +/-1Hz after pressing the lock button once. Then the red LED will turn off after pressing the lock button again.

NOTE: The Bodyguard will Auto Learn (green LED flashing) if the sensitivity  or pattern selection  or pattern depth  was changed during the set-up.

CHANGING THE ACCESS CODE FOR THE BODYGUARD

To change the access code from the factory default setting of 0000, you must complete the following:

1. Think of a 4-digit code that will be easy for you to remember.
2. Press the **1** button after making the necessary changes to the sensor. After pressing the **1** button, enter your 4-digit code that begins with the number one (1).
3. Each time you need to change the sensor settings, you must then press the **1** followed by the 4-digit code you have set.

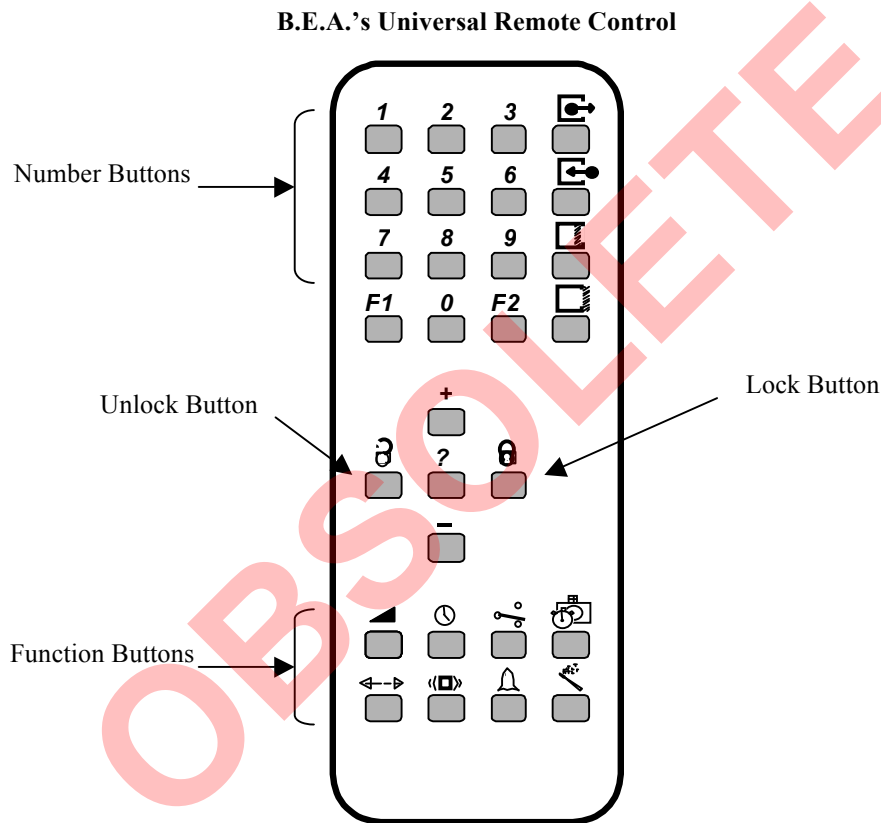

NON-REMOTE SETUP

Without the Universal Remote Control from B.E.A., Inc., the Bodyguard may be set up using the manual push buttons (see diagram below) located under the right end cap. Only the sensitivity, relay mode, auto-learn time, pattern width, and pattern depth may be adjusted with the manual push buttons. To adjust the Bodyguard, complete the following:

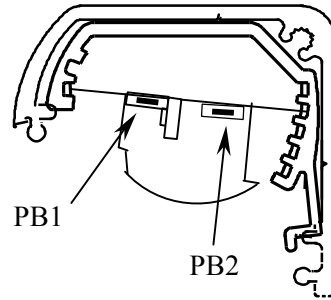

1. **To start the set-up process, press PB1 (for less than 2 seconds)**
 - The set-up function will be launched according to the current door position. The green LED will flash at 2+/- Hz for 10 seconds. This LED will stop flashing once a successful set-up is achieved.
 - If there is an interruption to the field of detection during this procedure, the green LED will flash at a slower rate. Press PB1 to relaunch the set-up.
2. **To change the detector's parameters, press PB1 (for more than 2 seconds), then release.**
3. **Press either PB1 or PB2. The LED will immediately flash red, followed by a sequence of green flashes.**
4. **The red flashes indicate the parameter and the green flashes indicate the setting of the particular parameter.**



NOTE: Pressing PB1 will toggle between the parameters and pressing PB2 will toggle between the range of adjustments for that particular setting. Once you achieve the highest adjustment, you will go back to the lowest setting by pressing PB2. For example, a value of zero (0) will not flash green; a value of one (1) will flash green one time.

5. **To exit manual set-up, simply wait 20 seconds or press PB1 for more than 2 seconds. Replace the right end cap back on the Bodyguard.**

RED LED STATUS	PARAMETER	SYMBOL	DESCRIPTION	GREEN LED STATUS
1 Red Flash	1		Sensitivity (Door open)	0 – 9 Green Flashes (default = 8)
2 Red Flashes	2		Sensitivity (Door closed)	0 – 9 Green Flashes (default = 8)
3 Red Flashes	3		Relay Mode	1 – 4 Green Flashes (default = 1)
4 Red Flashes	4		Auto Learn Time	0 – 9 Green Flashes (default = 0)
5 Red Flashes	5		Pattern Width (Door Open)	0 – 9 Green Flashes (default = 2)
6 Red Flashes	6		Pattern Width (Door Closed)	0 – 9 Green Flashes (default = 1)
7 Red Flashes	7		Pattern Depth (Door Open)	1 – 3 Green Flashes (default = 1)
8 Red Flashes	8		Pattern Depth (Door Closed)	1 – 3 Green Flashes (default = 1)

ONCE THE SET-UP PHASE IS COMPLETE (MANUAL OR REMOTE), WALK TEST THE FIELD OF DETECTION TO ENSURE ADEQUATE COVERAGE AND COMPLIANCE WITH ANSI STANDARDS.

BODYGUARD PATTERN CHARTS

The following charts correspond with the width and depth patterns of the Bodyguard. Keep in mind that zones 1-6 are the threshold area of the door, while zones 7-24 are the swing side of the door. To select a different width pattern, press the  button followed by the corresponding number. To select a different pattern depth, press  followed by the corresponding number.

1	2	3	4	5	6
7	8	9	10	11	12
13	14	15	16	17	18
19	20	21	22	23	24

(1) Wide Pattern

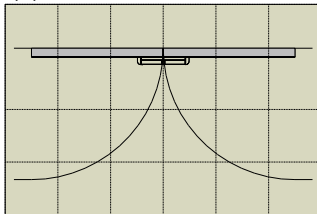

(2) Middle Pattern

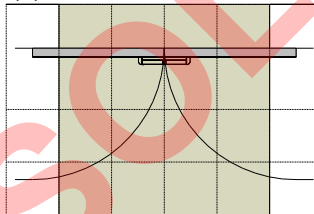

(3) Asymmetric Left Narrow

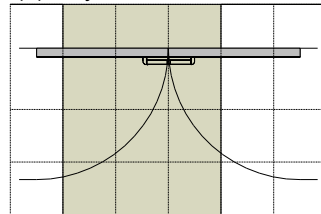

(4) Asymmetric Right Narrow

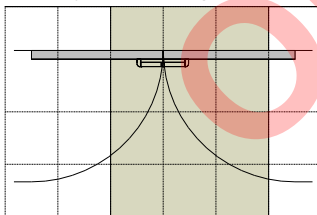

(5) Left Narrow

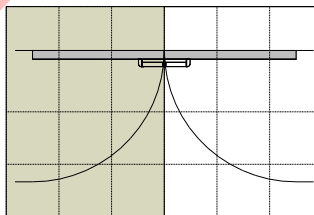

(6) Right Narrow

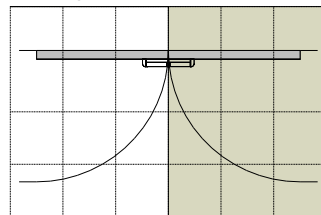

(7) Asymmetric Left Wide

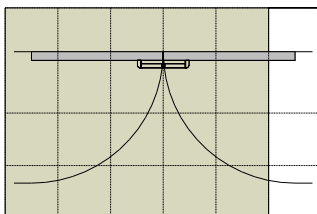

(8) Asymmetric Right Wide

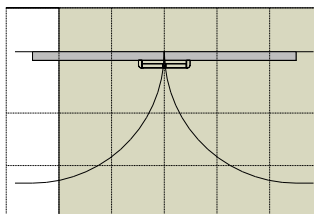

(9) Center Narrow

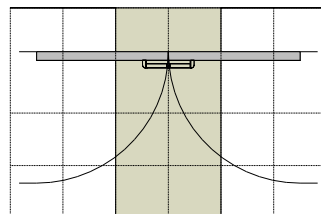

BODYGUARD DEPTH PATTERNS

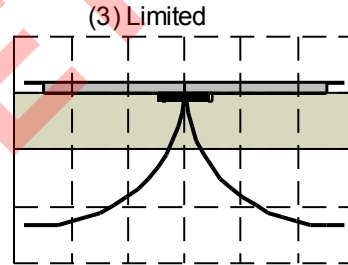
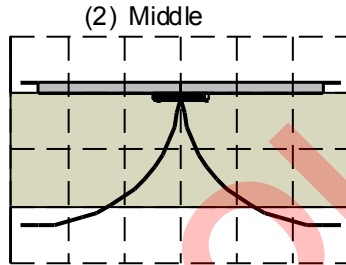
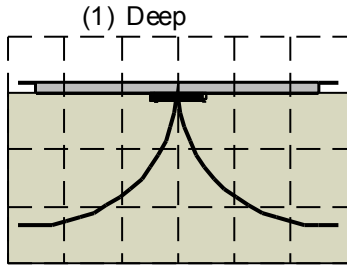
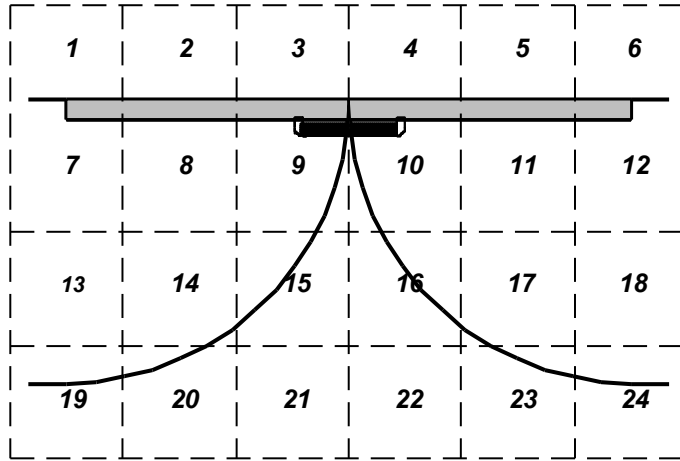

BODYGUARD TROUBLESHOOTING

BODYGUARD WILL NOT SET-UP UPON INITIAL POWERING

1. Check terminals 1 & 2 for proper voltage - 24 Volts AC/DC \pm 10%.
2. Make certain that the field of detection is all clear during the set-up and that all lenses are installed on the Bodyguard. If detection of movement is encountered upon initial set-up, the Bodyguard will continuously flash Green at \pm 2 Hz. The Bodyguard will also not set-up if permanent stationary objects are extremely close to the sensor. Ensure that, not only is the detection field all clear, but that the sensor is mounted properly (using the Bodyguard mounting block if necessary). If the mounting block is not used, and the backside of the sensor is less than 3" to the face of the door, it may be in saturation due to the door. Install the optional mounting block if necessary.
3. Ensure that all wiring connections have been properly made. Refer to wiring diagram on Page 8.
4. Ensure that no problems exist with the lockout device or the SBK-111 safety beams (if used).

BODYGUARD WILL NOT SET-UP AFTER PROGRAMMING

1. Ensure that no movement is occurring within the field of detection. If the Bodyguard detects movement beyond 20 seconds in it's field while set-up is taking place, the Green LED will begin flashing at a slower rate of \pm 1 Hz to indicate an unsuccessful set-up. Increase the angle of detection to 10° and try the set-up again. Make sure that all lenses are in place before initiating a set-up.
2. If the Bodyguard successfully completes a set-up upon powering, but then will not set-up after programming, reset all parameters to the factory default by pressing ****#** followed by number 4 or simultaneously pressing PB1 & PB2 at the right side of the Bodyguard (see page 11).
3. Start the programming procedure over, if successful set-up cannot be obtained thereafter, replace faulty Bodyguard.

DOOR WILL NOT OPEN ONCE SET-UP HAS BEEN COMPLETED

1. Check to ensure that there is no detection occurring at the Bodyguard. If the Red LED is on steady, there is detection. Make sure there have been no changes in the field of detection since set-up. If permanent changes have occurred, launch a new set-up and re-test door.
2. Check the setting of the Relay Mode. Relay should be set to Active Mode for most applications. Refer to page 10 "To Check A Setting" and perform Steps 1 & 2. When the relay is in the Active Mode, the relay contacts will be closed when the Red LED is on, and open when the Red LED is off. If the relay output, when tested with an Ohm Meter, is closed regardless of the Red Led, and the Relay Mode is set to Active Mode", replace faulty Bodyguard.
3. Disconnect Safety wire from door control. Activate door - if door still does not open, the fault lies within the automatic door control system, not the Bodyguard. If door does open, re-connect wires.
4. Disconnect the green & blue wires from the LO-21 to the door control safety and common terminals. If door opens when triggered, fault lies within the SBK-111 safety beam set, or possibly with the LO-21. Refer to the LO-21 troubleshooting procedures in the respective manual.

DOOR WILL NOT CLOSE OR BODYGUARD WILL NOT INHIBIT DURING CLOSING

1. If the Red LED is illuminated, launch a new set-up for the "door open" position. If Red LED goes out after Set-Up, walk-test the pattern and tune if necessary.
2. If Red LED comes back on when door goes open after new set-up, the Bodyguard may not be going into the "door open" pattern.
3. Ensure that Data wires are connected properly with respect to polarity.
4. Ensure that lockout devices are powered and operating normally.
5. Check for proper polarity between lockout device and operator motor.
6. If no problems are apparent with lockout device, replace faulty Bodyguard.

GREEN LED FLASHES STEADILY AT A RATE \pm 2Hz

1. If the Bodyguard has tried to launch a new set-up after the expiration of the Automatic Learn Time due to a permanent change in the field of detection, and there is continual movement in the field, the Bodyguard will flash the Green Led indefinitely until movement has stopped. This may also occur if there is an object that is extremely close to the Bodyguard, thereby causing saturation. Once the object or movement has been eliminated, clear the field of detection. The Bodyguard should set-up within 5 seconds and the Green LED should go out. Walking in and out of the detection field should cause the Red LED to come on and go out respectively thereafter.

RED LED FLASHES SLOWLY AT A RATE OF \pm 1 Hz

1. Unsuccessful set-up has occurred. Complete a new set-up according to Quick Reference Guide procedures on Page 3 of this instruction manual
2. If problem persists, return all parameters to the factory defaults by pressing  followed by number 3 or simultaneously pressing PB1 & PB2 at the right side of the Bodyguard (page 13).
3. Launch a new set-up. If Red LED continues to flash slowly, replace faulty Bodyguard.

RED LED DOES NOT FLASH WHEN UNLOCKING FROM THE REMOTE CONTROL

1. Replace faulty batteries in Remote Control
2. If problem persists, the remote control or the Bodyguard may be faulty. If possible, test the remote control on a known good B.E.A. sensor. If remote control works, replace faulty Bodyguard, if not, replace the remote control. At this point set-up may be accomplished according to page 13, "Non Remote Set-Up & Tuning Using Buttons Located Under Right End Cap".

OBSOLETE

If after troubleshooting a problem, a satisfactory solution cannot be achieved, please call B.E.A., Inc.
for further assistance during Eastern Standard Time at
1-800-523-2462 from 7am - 5pm or 1-800-407-4545 from 5pm - midnight & weekends.

DO NOT leave any problem unresolved. If you must wait for the following workday to call B.E.A., leave the door inoperable until satisfactory repairs can be made. **NEVER** sacrifice the safe operation of the automatic door or gate for an incomplete solution.