

CYLINDRICAL UNIVERSAL ELECTRIC STRIKE

Cylindrical electric strike for access doors



Visit website for available languages of this document.

DESCRIPTION

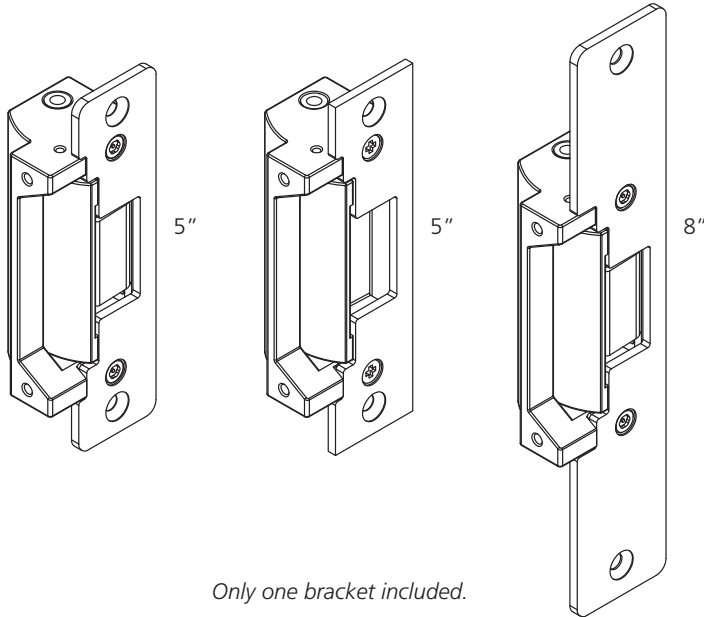

Only one bracket included.

TECHNICAL SPECIFICATIONS

Operating voltage	12 or 24 VDC
Current draw	300mA (12 VDC) 150mA (24 VDC)
Operating temperature	32 – 120 °F (0 – 49 °C)
Humidity	0 – 85% non-condensing
Latch throw	$\frac{9}{16}$ " (15mm) max.
Keeper width	1 $\frac{5}{17}$ " (36mm)
Static strength	1000 lbs (454kg)
Dynamic strength	50 ft-lbs
Endurance	250,000 cycles (UL-tested) 1,000,000 cycles (factory-tested)
Material (strike body)	zinc alloy / stainless steel

Specifications are subject to change without prior notice.
All values measured in specific conditions.

The CYLINDRICAL UNIVERSAL ELECTRIC STRIKES are designed to accommodate either cylindrical or mortise locksets up to $\frac{9}{16}$ " (15mm) throw latchbolt. When installed with a fail secure manner, the local authority shall be consulted with regard to the use of possible panic hardware to allow emergency exit from the secured area.

UL294 & UL1034 REQUIREMENTS

- Indoor use only.
- Wiring methods shall be in accordance with NFPA70.
- 10STRIKECUV is intended to be used with UL-listed exit hardware.
- 10STRIKECUV shall not impair the intended operation of an emergency exit.
- 10STRIKECUV shall not impair the operation of panic hardware mounted on the door.

GENERAL SAFETY



- Shut off all power going to header before attempting any wiring procedures.
- Maintain a clean and safe environment when working in public areas.
- Constantly be aware of pedestrian traffic around the door area.
- Always stop pedestrian traffic through the doorway when performing tests that may result in unexpected reactions by the door.
- ESD (electrostatic discharge)*: Circuit boards are vulnerable to damage by electrostatic discharge. Before handling any board, ensure you dissipate your body's ESD charge.
- Always check placement of all wiring before powering up to ensure that moving door parts will not catch any wires and cause damage to equipment.
- Ensure compliance with all applicable safety standards (i.e. ANSI A156.10) upon completion of installation.
- DO NOT attempt any internal repair of the components. All repairs and/or component replacements must be performed by BEA, Inc. Unauthorized disassembly or repair:
 1. May jeopardize personal safety and may expose one to the risk of electrical shock.
 2. May adversely affect the safe and reliable performance of the product resulting in a voided warranty.

MOUNTING & WIRING

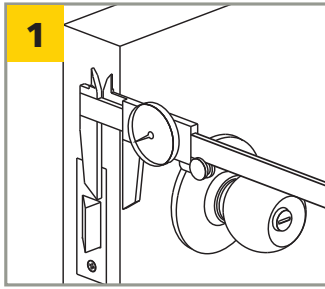

1 Measure latch position.

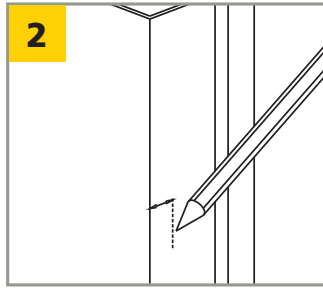

2 Mark latch position line.

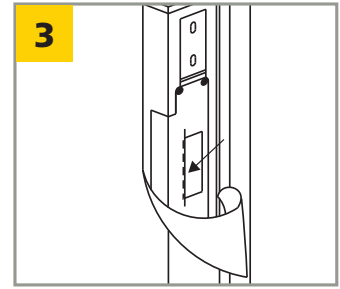

3 Attach sticker template to marked centerline.

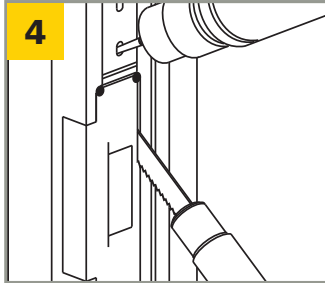

4 Cut hole using template.

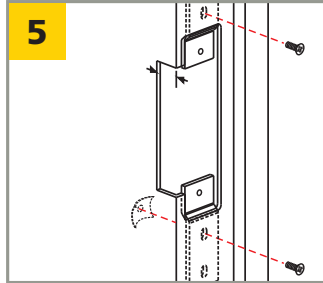

5 Install mounting tabs.

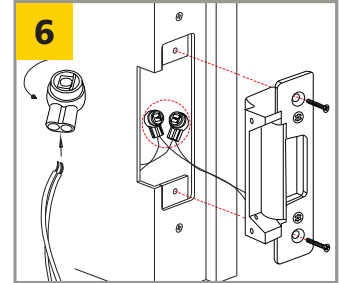

6 Connect wires using crimp connections. Test strike, ensuring it is receiving correct voltage.

Proper gap must be reserved between the strike keeper and latch bolt to prevent failure of solenoid valve.

Connection Diagram

12 VDC operation

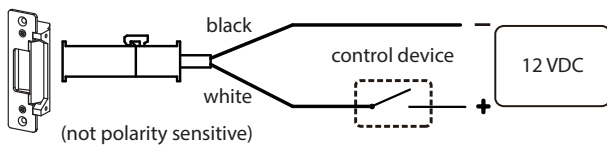

24 VDC operation

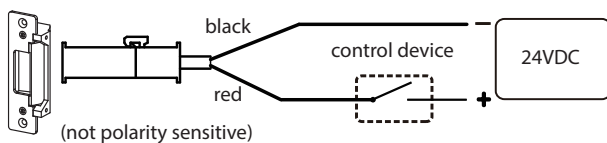

Fail-safe / Fail-secure Reversible

Fail-safe and fail-secure are changeable by moving the position of the locking screws.

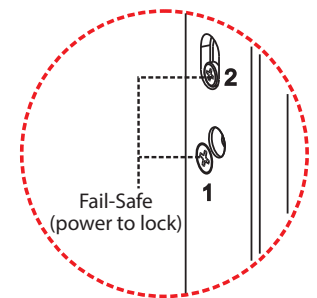
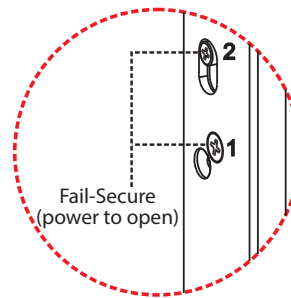

BEA, INC. INSTALLATION/SERVICE COMPLIANCE EXPECTATIONS

BEA, Inc., the sensor manufacturer, cannot be held responsible for incorrect installations or incorrect adjustments of the sensor/device; therefore, BEA, Inc. does not guarantee any use of the sensor/device outside of its intended purpose.

BEA, Inc. strongly recommends that installation and service technicians be AAADM-certified for pedestrian doors, IDA-certified for doors/gates, and factory-trained for the type of door/gate system.

Installers and service personnel are responsible for executing a risk assessment following each installation/service performed, ensuring that the sensor/device system installation is compliant with local, national, and international regulations, codes, and standards.

Once installation or service work is complete, a safety inspection of the door/gate shall be performed per the door/gate manufacturer's recommendations and/or per AAADM/ANSI/DASMA guidelines (where applicable) for best industry practices. Safety inspections must be performed during each service call – examples of these safety inspections can be found on an AAADM safety information label (e.g. ANSI/DASMA 102, ANSI/DASMA 107).

Verify that all appropriate industry signage and warning labels are in place.

